

# CLASSICAL VENTURI TUBES

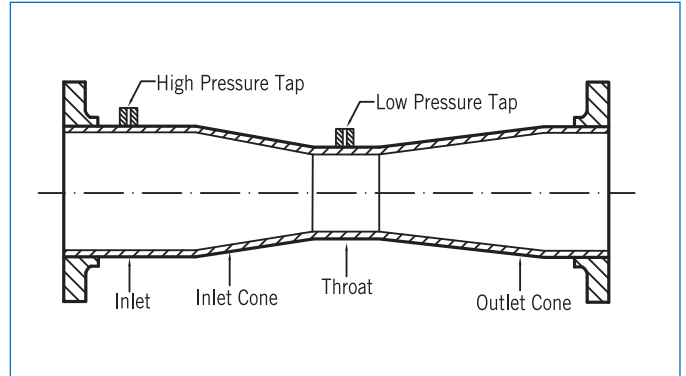

*Classic Venturi Tube*



The classical venturi tube consists of a straight inlet section of the same diameter as the pipe and in which the high pressure tap is located a converging conical inlet section in which the cross section of the stream decreases and the velocity increases with a consequent increase of velocity head and decrease of pressure head.

The pressure taps are located one-quarter to one-half pipe diameter upstream of the inlet cone and at the middle of the throat section.

### Technical Data

- ISO-5167-4 standard
- Diameter ratio  $\beta$  : 0.3~0.75
- Minimum recommended reynold number: 75,000
- Minimum recommended pipe I.D: 3" (75mm)
- Size: 3" ~ 42" available
- Material: A105, steel, stainless steel, available. Special material on request.

### Venturi Pressure Loss

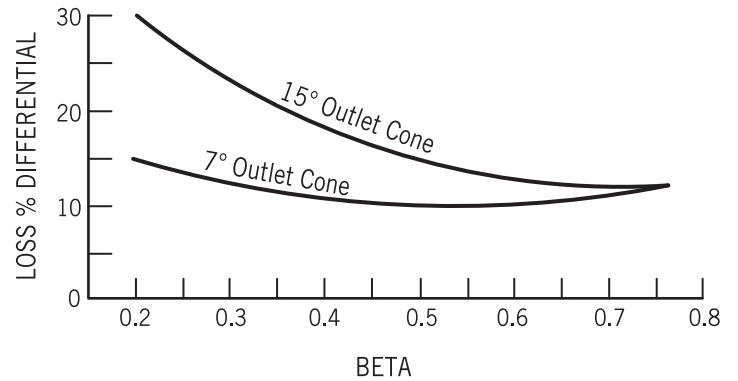

### Representative Schematic

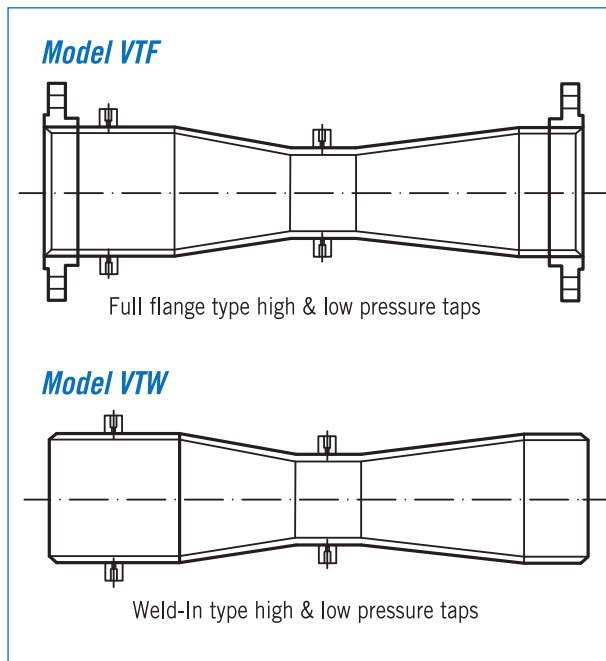

### Pressure Loss Curves

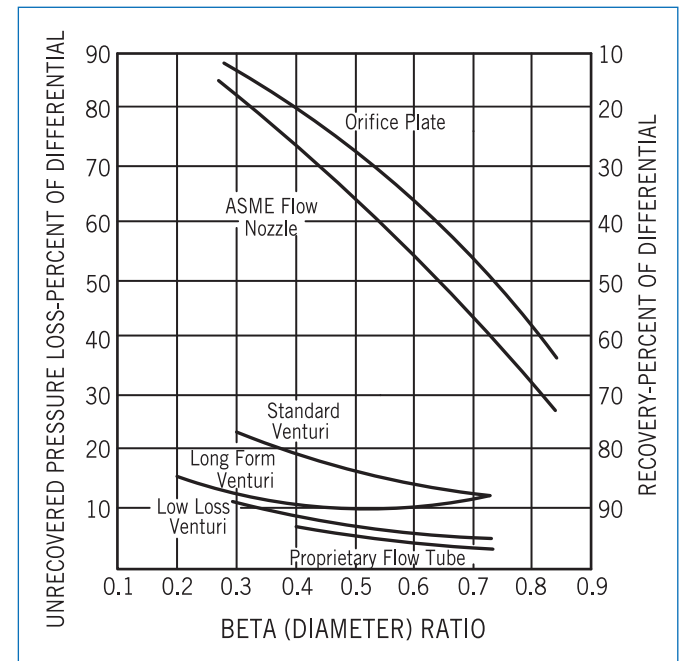

**ISO Standard 5167 Required**

**Straight Lengths for Orifice Nozzle ISA Venturi Nozzle and Venturi in Multiples of Pipe Diameter D**

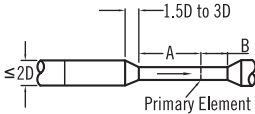
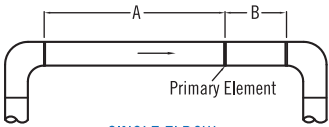
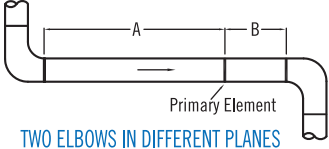
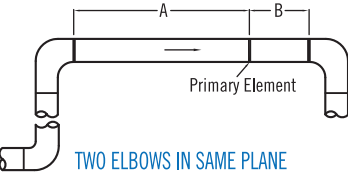
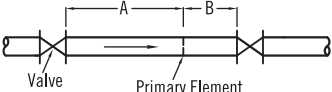
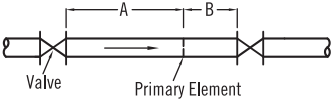
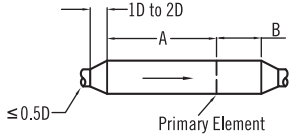
Upstream disturbance	Dimension	Device	$\beta$							
			0.2	0.3	0.4	0.5	0.6	0.7	0.75	
 <p><b>REDUCER</b></p>	A	Orifices Nozzles	5	5	5	6	9	14	22	
		Venturis		0.5	2.5	5.5	8.5	10.5	11.5	
 <p><b>SINGLE ELBOW</b></p>	A	Orifices Nozzles	14	16	18	20	26	28	36	
		Venturis		0.5	0.5	1.5	3	4	4.5	
 <p><b>TWO ELBOWS IN DIFFERENT PLANES</b></p>	A	Orifices Nozzles	34	34	36	40	48	62	70	
		Venturis		0.5	0.5	8.5	17.5	27.5	29.5	
 <p><b>TWO ELBOWS IN SAME PLANE</b></p>	A	Orifices Nozzles	14	16	18	20	26	36	42	
		Venturis		1.5	1.5	2.5	3.5	4.5	4.5	
 <p><b>GATE VALVE, FULLY OPEN</b></p>	A	Orifices Nozzles	12	12	12	12	14	20	24	
		Venturis		1.5	2.5	3.5	4.5	5.5	5.5	
 <p><b>GLOBE VALVE, FULLY OPEN</b></p>	A	Orifices Nozzles	18	18	20	22	26	32	36	
		Venturis								
 <p><b>EXPANDER</b></p>	A	Orifices Nozzles	16	16	16	18	22	30	38	
		Venturis		1.5	1.5	2.5	3.5	5.5	6.5	
Downstream length for all Pictured disturbances	B	Orifices Nozzles	4	5	6	6	7	7	8	
		Venturis		4d	4d	4d	4d	4d	4d	4d

## Orifice / Nozzle / Venturi Tube Installed Guide

**Liquid**  
DP-Flow Element  
 With 3-way manifold.

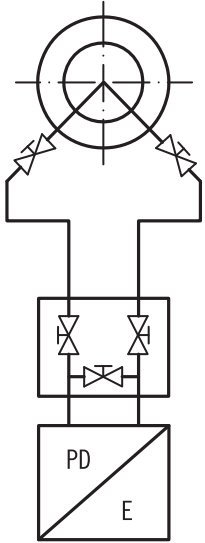

**Steam**  
DP-Flow Element  
 With 5-way manifold and  
 condense pots

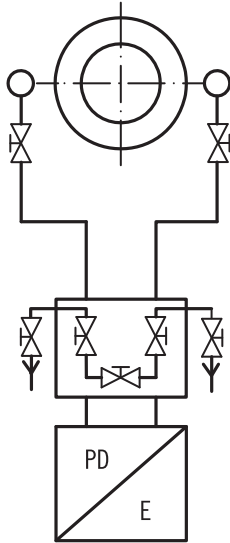

**Dry Gas**  
DP-Flow Element  
 With 3-way manifold

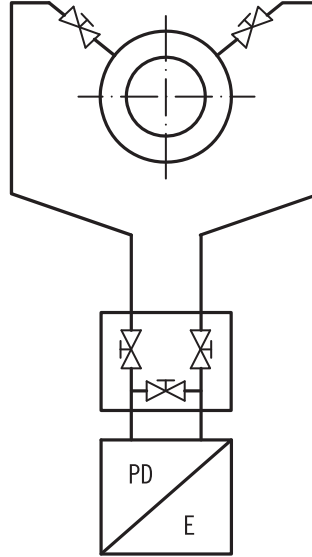

**Humid Gas**  
DP-Flow Element  
 With 3-way manifold and  
 drain pot

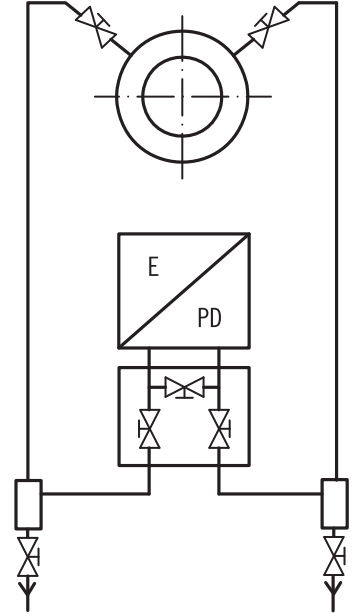

**Steam**  
DP-Flow Element on  
 top mounting  
 With condense pots

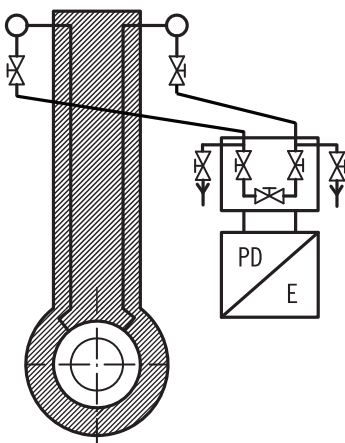

**Liquid**  
DP-Flow Element on  
 top mounting  
 With 3-way manifold and  
 vent valves

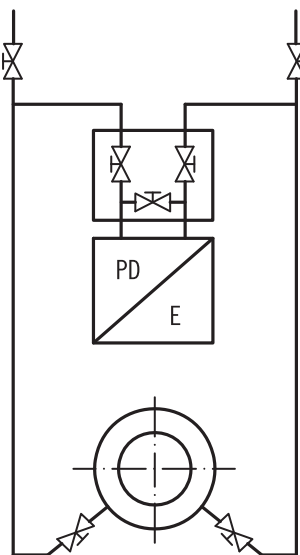

**Gas, dry and humid**  
DP-Flow Element on  
 top mounting  
 With 3-way manifold

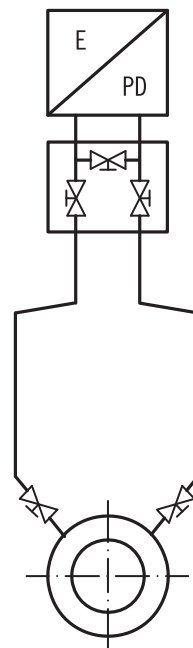

**Gaseous Fluid**  
DP-Flow Element on  
 top mounting  
 With 3-way manifold and  
 vent pots

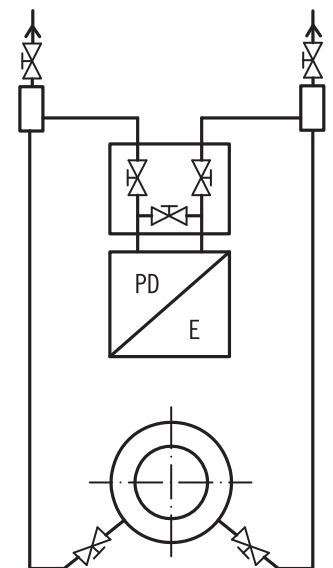

**Ordering Information**

Individual Specification				Requirement		Requirement	
1	Model No.						
2	P&ID No.						
3	Line No.						
4	Service						
<b>Meter</b>							
5	Type of Element						
6	Size & Process Connection						
7	Pressure Taps						
8	Taps Connection						
9	Wetted Parts Material						
10	Condensate or Sealing Chamber						
11	Diff. Pressure (mmH <sub>2</sub> O)	Design	Calculated				
12	Beta Ratio	Design	Calculated				
13	Calculation STD	Design	Calculated				
14	Painting						
15	Fluid	Phase					
16	Flow Range	Flow unit					
17	Flow Rate	Max.	Nor.				
18	Temp. (°C)	Max.	Nor.				
19	Press. (kg/cm <sup>2</sup> G)	Max.	Nor.				
20	Viscosity @Cp	Cp/Cv					
21	SpGr @Cp./@Base	Mol. Wt.					
22	Pipe Size (mm)	I.D	O.D				
23	Pipe Material	Pipe Schedule No.					
24	Max. Permissible Pressure Loss (mmH <sub>2</sub> O)						
25	Tag No.						

\* Please fill in above block on request.