

**Thank you for choosing a NIVELCO instrument.
We are sure that you will be satisfied throughout its use!**

1. INTRODUCTION

The **UNICONT PGK-301 Ex** DIN rail mountable intrinsically safe isolator and power supply modules are suitable for providing power supply for 2-wire transmitters operating in hazardous applications, as well for isolating the input, output and supply voltage galvanically. Moreover the device perform high accuracy signal transmission between Ex and non-Ex areas. The data transmission can be 4-20/4-20 mA or 2-way digital HART depending on model type. The **UNICONT PGK-301 Ex** intrinsically safe isolators perform signal transmission to the non-Ex Zone with microprocessor controlled digital sign-processing which provides high transmission accuracy. This is a special demand in case of certified, high precision (for example magnetostrictive) transmitters. If fast conversion speed is necessary, the high speed types are recommended. The number of connectable transmitters is determined by the intrinsically safe limit data!

2. TECHNICAL DATA

2.1 GENERAL DATA

Type	High precision		High speed	
	PGK-301-A Ex	PGK-301-B Ex	PGK-301-C Ex	PGK-301-D Ex
Input	4-20 mA			
Output	4-20 mA			
	3.6 mA: $I_{IN} = 3.6 \text{ mA}$ or $I_{IN} > 24 \text{ mA}$			
Protection	Input, output, power supply: 125 mA fuse			
Loop resistance	300 - 1000 Ohm / 24V DC			
Communication	-	HART	-	HART
Power supply	20 - 35 V DC			
Power supply indication	green LED			
Power supply for transmitters	24 V DC galvanically isolated			
Galvanic isolation	> 2 kV			
Power consumption	Max. 2.2 W			
Transmission accuracy	1 μA (at 20 °C)		8 μA (at 20 °C)	
Response time	100 msec.		5 msec.	
Temperature dependence	< 1 μA / °C			
Ambient temperature	- 20 °C...+ 60 °C			
Electrical connection	Terminal, wire cross section: 0.5 – 2.5 mm ²			
Electrical protection	Class III.			
Mechanical connection	DIN EN 50022-35 rail mountable, module width: 22.5 mm			
Mass	0.25 kg			

2.2 SPECIAL DATA FOR EX CERTIFIED MODELS

Type	PGK-301-A Ex, PGK-301-C Ex, PGK-301-B Ex, PGK-301-D Ex		
Ex marking	ATEX	$\text{Ex II (1) G [Ex ia Ga] IIC}$	$\text{Ex II (1) G [Ex ia Ga] IIB}$
	IEC Ex	$[\text{Ex ia Ga}] \text{IIC}$	$[\text{Ex ia Ga}] \text{IIB}$
Intrinsically safe limit data	$L_o = 2 \text{ mH}$ $C_o = 60 \text{ nF}$		$L_o = 9 \text{ mH}$ $C_o = 450 \text{ nF}$
	$U_o = 26 \text{ V}$ $I_o = 94 \text{ mA}$ $P_o = 0,65 \text{ W}$		
	$U_m = 253 \text{ V AC}$		

2.3 ACCESSORIES

- User's manual,
- Warranty Card,
- Declaration of Conformity

2.4 ORDER CODE

UNICONT PGK – 301 –

FUNCTION / OUTPUT	CODE
High precision / 4-20 mA	A
High precision / 4-20 mA +HART	B
High speed / 4-20 mA	C
High speed / 4-20 mA +HART	D

2.5 DIMENSIONS

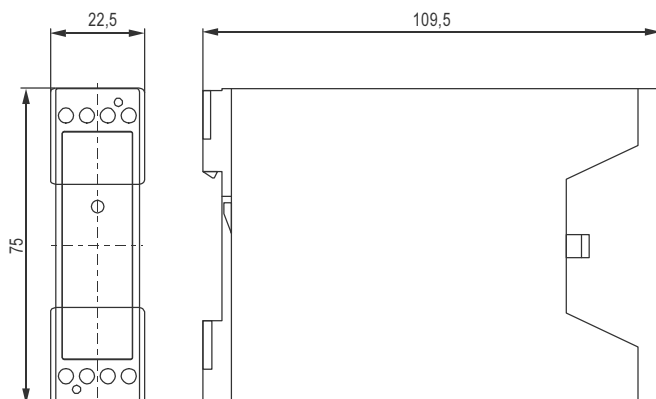

UNICONT

PGK-301-Ex
INTRINSICALLY SAFE
ISOLATOR / POWER SUPPLY MODULE

USER'S MANUAL

NIVELCO



3. WIRING

Number of the connectable transmitters is determined by the intrinsically safe limit data (transmitters + cables), along with the min. supply voltage of the transmitters.

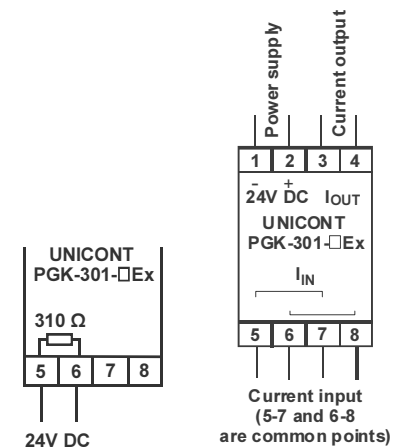

To provide proper HART communication in case of HART-capable transmitters, the maximal allowed C_o values are the following:

IIB	IIC
$C_o = 450 \text{ nF}$	$C_o = 60 \text{ nF}$

Calculation example to determine the number of connectable transmitters:

I_{IN} : 4 mA (HART!)

C_i : 10 nF

Supply voltage of the transmitter: min. 12.5 V

Cable capacitance: 10 nF

Cable resistance: 10 Ohm

In case of a transmitter and wiring with the above technical specifications the calculation can be the following:

<p>for Group IIC rated transmitters:</p> <p>Number of connectable devices: max. 5 pcs. because: 5 transmitters x 4 mA = 20 mA (310 Ohm + 10 Ohm) x 20 mA = 6.4 V</p> <p>Supply voltage of the transmitter: 24 V – 6.4 V = 17.6 V > 12.5 V $C_i = 5 \times 10 \text{ nF} = 50 \text{ nF} + 10 \text{ nF}$ max. cable capacitance = 60 nF</p> <p>Of course if cable capacitance is greater, then only fewer transmitters are allowed to be connected!</p>	<p>for Group IIB rated transmitters:</p> <p>Number of connectable devices: max. 8 pcs. because: 8 transmitters x 4 mA = 32 mA (310 Ohm + 10 Ohm) x 32 mA = 10.24 V</p> <p>Supply voltage of the transmitter: 24 V – 10.24 V = 13.76 V > 12.5 V $C_i = 8 \times 10 \text{ nF} = 80 \text{ nF} + 10 \text{ nF}$ max. cable capacitance = 90 nF < 450 nF</p> <p>Of course if cable resistance is greater, then only fewer transmitters are allowed to be connected!</p>
--	--

It is clearly visible, that the max. number of the transmitters allowed to be connected to a single unit is depended on the cable capacitance in case of IIC rated transmitters, and it is depended on the cable resistance in case of IIB rated transmitters.

4. RECOMMENDED WIRING EXAMPLES

Wiring of 2-wire, 4-20 mA transmitter connected to a passive current loop

The 4 - 20 mA I_{OUT} is a passive current loop, therefore it needs external power supply.

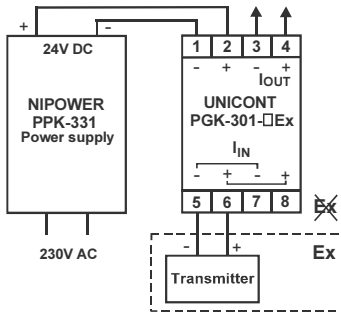

Wiring of 2-wire, 4-20 mA transmitter connected to an active current loop

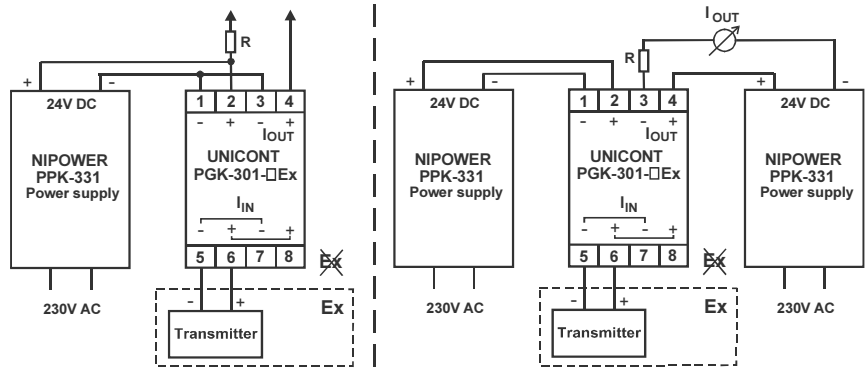

The 4 - 20 mA I_{OUT} is an active current loop, it is supplied by the NIPOWER PPK-331 power supply module.

Wiring of 2-wire, HART-capable transmitter connected to a HART modem

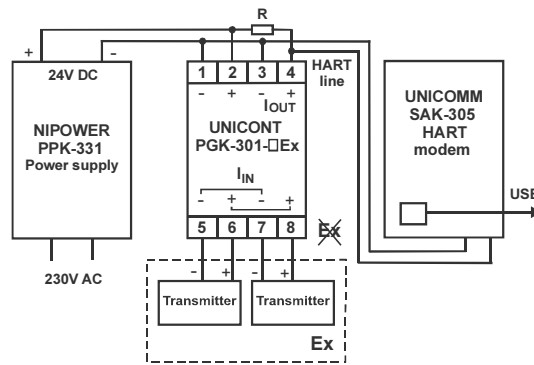
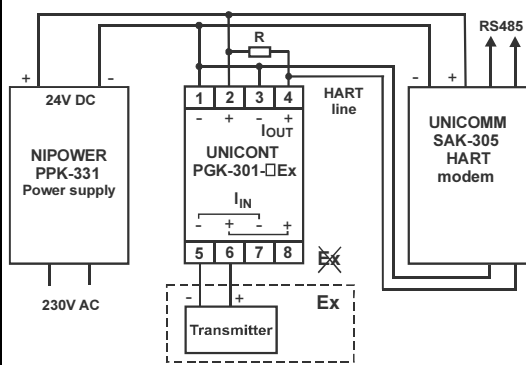

Wiring of two UNICONT PGK-301-□Ex isolator modules connected to multiple 2-wire HART-capable transmitters

Note: All transmitters should have different HART short-addresses!

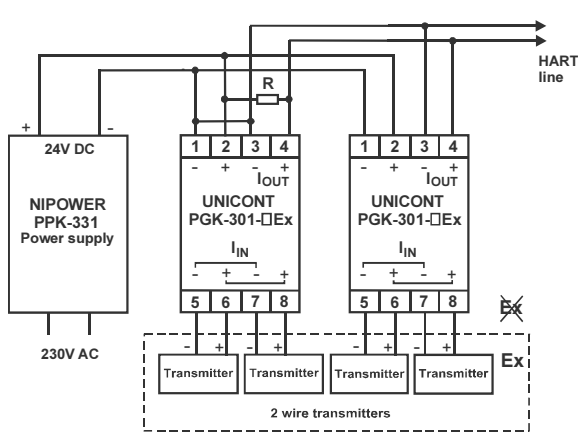

$R = 300 \text{ Ohm} / 2W \dots 1 \text{ kOhm} / 2 \text{ W}$ should be between these values depending on the number of the applied isolator modules. It should be connected to only one unit! Resistance value of the necessary resistor can be calculated by the help of the following formula:

$$R[\text{Ohm}] = \frac{24[V] - 7[V]}{\sum I_{IN} [A]}$$

5. OPERATION

The unit is fully operational after the mounting and the wiring. The green LED on the front panel indicates the 24V DC power supply voltage.

When the input current (I_{IN}) is greater than 24 mA, then the output current (I_{OUT}) will be limited to 3.6 mA which is the current error. The power supply rail, as well the current input and output rails are protected against overvoltage, or overcurrent by a 125 mA fuse.

If the fuse of the power supply rail has been melted, the POWER LED goes dark, in case when the other fuses have been melted, the POWER LED will light, but the device will not be operational.

6. MAINTENANCE, REPAIR

The unit does not require regular maintenance. All repairs will be carried out at the manufacturer's premises.

7. STORAGE

Ambient temperature: -30 °C ... + 60 °C
Relative humidity: max. 98%

8. WARRANTY

NIVELCO provides warranty of 3 (three) years in compliance with details described in the Warranty Card.

pgk301aa0600h_03

2012. May

NIVELCO reserves the right to change technical data without notice!