

Smart level probes SGE-25.Smart and SGE-25S.Smart

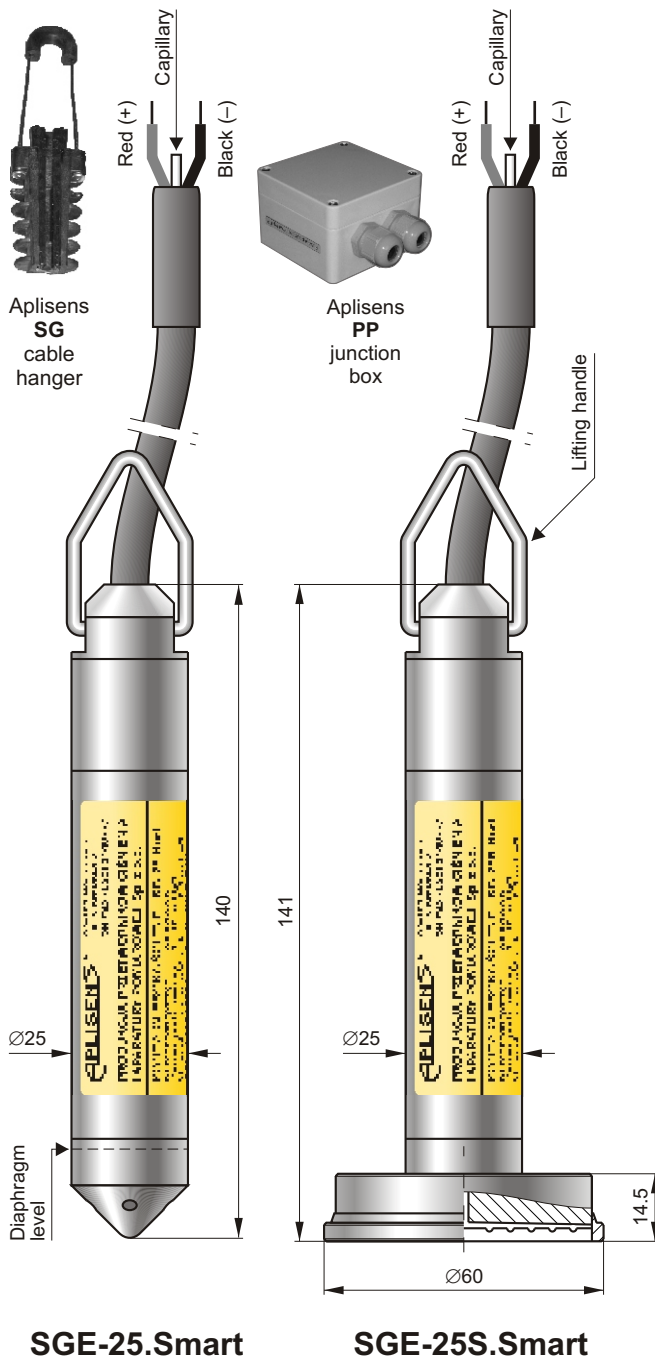

- ✓ Programmable zero shift, range and damping ratio
- ✓ 4...20 mA output signal + HART protocol
- ✓ Accuracy 0.1%
- ✓ Integrated internal overvoltage protection circuit
- ✓ ATEX Intrinsic safety Ex II 1G Ga Ex ia IIC T4/T5/T6 I M1 EEx ia I
- ✓ Titanium version (SGE-25S.Smart)
- ✓ Marine certificate DNV

Application

The SGE-25.Smart level probe is applicable to measure liquid levels in tanks, deep wells or piezometers.

The SGE-25S.Smart probe is applicable to measure levels of liquids containing contaminants or suspensions. A typical use for this probe is the measurement of levels of liquid waste in intermediate pumping stations, fermentation chambers, settling tanks etc.

Principles of operation, construction

The probe measures liquid levels, basing on a simple relationship between the height of the liquid column and the resulting hydrostatic pressure. The pressure measurement is carried out on the level of the separating diaphragm of the immersed probe and is related to atmospheric pressure through a capillary in the cable.

The active sensing element is a piezoresistant silicon sensor separated from the medium by an isolating diaphragm. The electronic amplifier, which works in combination with the sensor, is additionally equipped with an overvoltage protection circuit, which protects the probe from damage caused by induced interference from atmospheric discharges or from associated heavy current engineering appliances.

Configuration

The following metrological parameters can be configured:

- ◆ The units of pressure;
- ◆ Start and end-points of set range;
- ◆ damping time constant;
- ◆ inverted characteristic (output signal 20 ± 4 mA).

Calibration

It is possible to calibrate the probe in relation to a model pressure.

Communication

The communication standard for data interchange with the probe is the Hart protocol.

Communication with the probe is carried out with:

- a KAP-03 communicator,
- some other Hart type communicators,
- a PC using an RS-HART converter and RAPORT-02 configuration software.

The data interchange with the probe also enables the users to:

- ◆ identify the probe;
- ◆ read the currently measured hydrostatic pressure value, output current and percentage of measuring range.

Installation, method of use

When lowered to the reference level, the probe may either hang freely on the cable or lie on the bottom of the tank. The cable with the capillary can be extended using a standard signal cable. For the cable connection a special Aplisens **SG** cable hanger is recommended. The cable connection should be situated in a non-hermetically sealed box (the internal pressure inside the box should be equal to the atmospheric pressure), preventing water or other contaminants from getting into the capillary. The Aplisens **PP** junction box is recommended. For systems with long signal transmission lines, it is recommended the using of an addi-

tional Aplisens UZ-2 overvoltage protection circuit in the form of a wall-mounted box which allows the cables connection. When the probe cable is being wound up, the minimum winding diameter should be 30cm and the cable should be protected from mechanical damage.

If there is a possibility of turbulence in the tank (for example, because of the mixer operating mixers or a turbulent inflow), the probe should be installed inside a screening tube (e.g. made of PVC). The line hooked on the lifting handle can simplify the operation of the probe pulling out. Cleaning the probe diaphragm by mechanical means is strictly prohibited.

Measuring ranges

No.	Nominal measuring range (FSO)	Maximum range (measurement limit)	Minimum set range	Overpressure limit (without hysteresis)
1	0...10 m H ₂ O	-1...11.5 m H ₂ O	0.8 m H ₂ O	100 m H ₂ O
2	0...100 m H ₂ O	-5...115 m H ₂ O	8 m H ₂ O	700 m H ₂ O

Technical data

Metrological parameters

Accuracy	≤ ±0.1% for nominal range
SGE-25.Smart	≤ ±0.3% for range 0...10% FSO
Long term stability	≤ 0.1% (FSO) for 2 years
Accuracy	≤ ±0.16% for nominal range
SGE-25S.Smart	≤ ±0.4% for range 0...10% FSO
Thermal error	< ±0.08% (FSO) / 10°C max ±0.25% in the whole compensation temp. range
For the SGE-25S.Smart probe the use of a diaphragm seal causes an additional absolute zero error, related to changes in the medium temperature, of up to 80 Pa / 10°C	
Thermal compensation range	-25...80°C
Time Constant	0.3 s
Additional electronic damping	0...30 s
Error due to supply voltage changes	0.002% (FSO) / V

Special versions:

- ◇ **EEx** – ATEX Intrinsic safety
- ◇ **Teflon** – Teflon cable shielding
- ◇ **Titanium** – titanium wetted parts
- ◇ **MR** – Marine certificate DNV
- ◇ **1.5 m H₂O** – Probe for nominal range 0...1.5 m H₂O (Accuracy 0.16%)

Ordering procedure

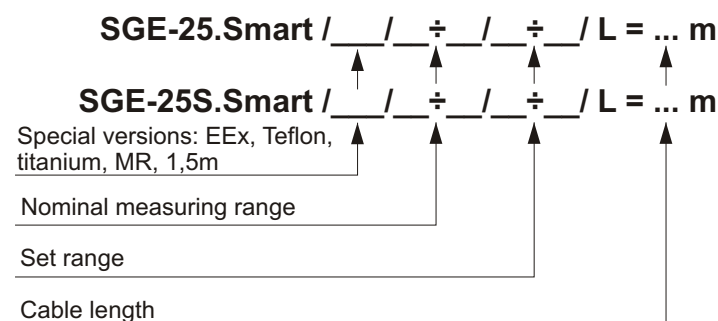

Fitting accessories if required: **SG** cable hanger, **PP** junction box

Example: SGE-25.Smart probe, Teflon cable shielding, nominal measuring range 0 ÷ 10 m H₂O, set range 0 ÷ 3.25 m H₂O, cable 10 m

SGE-25.Smart / Teflon / 0 ÷ 10 m H₂O / 0 ÷ 3.25 m H₂O / L = 10 m

Electrical parameters

Power supply	10.5...36 V DC (EEx 12...28 V DC)
Output signal	4...20 mA (two wire transmission)
Load resistance	$R[\Omega] \leq \frac{U_{in}[V] - 10.5V}{0.02A} \cdot 0.85$
Resistance required for communication	250...1100 Ω

Operating conditions

Medium temperature range

- 30...80°C for basic range 0...10 m H₂O
- 30...50°C for basic range 0...100 m H₂O

CAUTION: The medium must not be allowed to freeze in the immediate vicinity of the probe.

Degree of protection	IP-68
Material of casing and diaphragm	316Lss (for SGE-25 Smart diaphragm Hastelloy) Titanium – special version (only SGE-25S.Smart)
Cable shield	POLYURETHANE

The manner of communicator connection

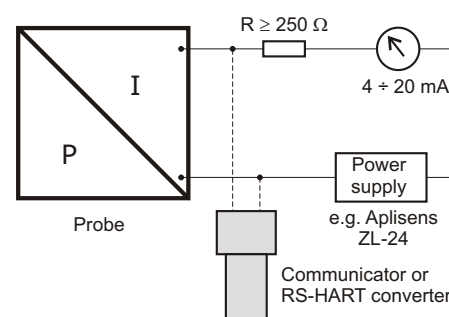

Smart hydrostatic level probe types SGE-25.Smart/Modbus and SGE-25S.Smart/Modbus

NEW

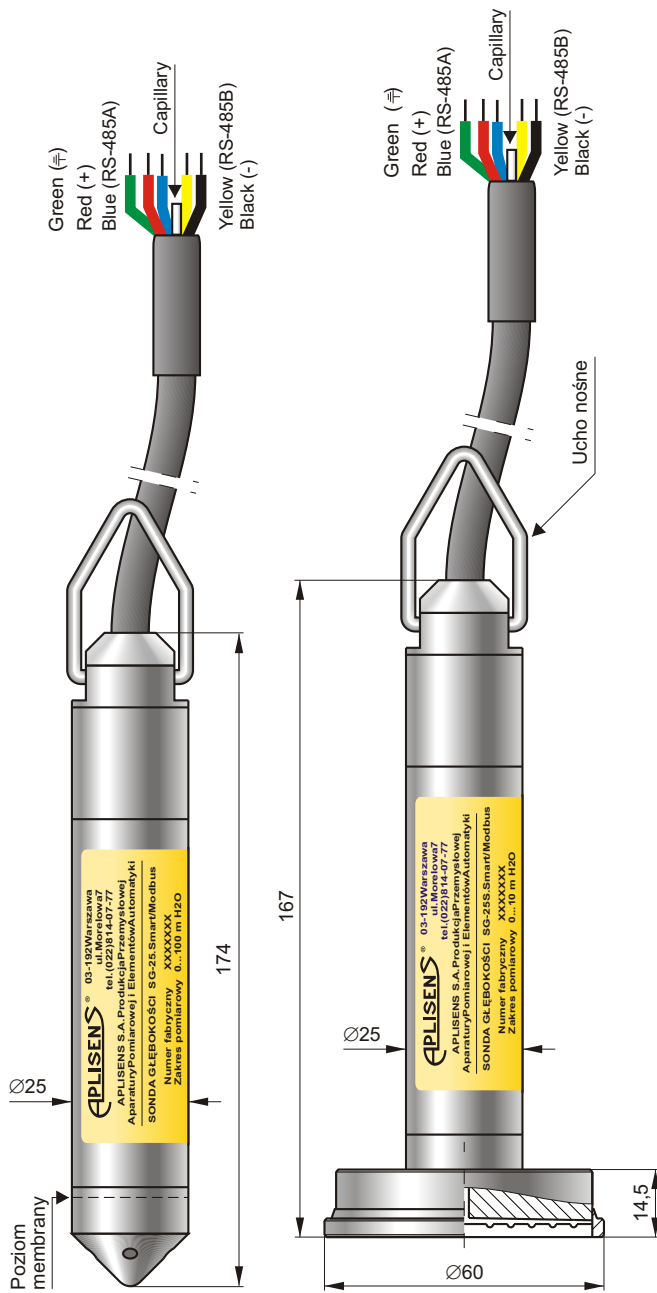

SGE-25.Smart/Modbus SGE-25S.Smart/Modbus

Electrical connection

	Function	PM12 connector
Power	GND	3
	+Vcc	4
Digital	RS-485A	2
	RS-485B	1

Communication

Level probes with communication protocol Modbus RTU. The communication standard for data interchange with the transmitter is the Modbus RTU. Communication with the transmitter is carried out with PC using RS converter and Aplisens software.

Technical data*

Metrological parameters

Accuracy	≤ ±0,1%
Long-term stability (for nominal range)	≤ accuracy for 3 years
Thermal error	< ±0,1% (FSO) / 10°C max ±0,4% (FSO) in the whole compensation range
Thermal compensation range.	-25...80°C (other range on request)
Additional electronic damping	0...30 s

Electrical parameters

Power supply	6...28 V DC
Transmission range	1200 m
Transmission protocol	MODBUS RTU
Address space	1...247 devices address
Transmission speed	600...115200 bps
Parity transmission	no parity, odd, even
frame transmission	10...11 bitów (1, 2 bit-stop)

*more information about technical data available in user's manual

Please note:

- Version PCE-28/Modbus is not available with ATEX certificate.

Special version

- ◇ **Teflon** – teflon cable shielding
- ◇ **Hastelloy** – Hastelloy C-276 diaphragm in SGE-25S.Smart/Modbus

Ordering procedure

SGE-25.Smart/Modbus / / / L = ... m

SGE-25S.Smart/Modbus / / / L = ... m

Spec. Version.: Teflon, Hastelloy

Set range

Cable length

Example: level probe SGE-25.Smart/Modbus, teflon cable shielding, set range 0 ÷ 10 m H₂O, cable length 10 m
SGE-25.Smart / Modbus / Teflon / 0 ÷ 10 m H₂O / L = 10 m