

ORIFICE FLANGES AND ORIFICE PLATE

All the NEW-FLOW orifice unions are manufactured according to the software by Flow Soft inc. The following is a list of commonly used standards and references used in flow measurement calculations:

- Flow Measurement Engineering Handbook. 2nd edition. R.W. Miller.
- Principles and practice of Flow Meter Engineering. 9th edition. L.K. Spink.
- Fluid Meters, Their Theory and Application. 6th edition, Howard S. Bean.
- Measurement of Fluid Flow in Pipes Using Orifice, Nozzle, and Venturi, ASME MFC-3M-1985.
- Measurement of fluid flow by means of pressure differential devices-Orifice plates, inserted in circular cross section conduits running full, ISO 5167-2-2003.
- Orifice Metering of Natural Gas and Other Related Hydrocarbon Fluids, AGA Report 3, API 2000,2003.

Technical Data

Orifice Plate Series: Restriction plate. Concentric orifice plate. Quadrant edge orifice plate. Conical entrance orifice plate. Large and small orifice plate. Eccentric orifice plate. Segmental orifice plate. Ring-joint orifice plate. Screw type ring-joint orifice plate. Corner type plate.

Orifice Tap Series: (a) flange taps. radius or D-D/2 taps, vena contract taps. and pipe taps. (b) corner tap-individual pressure tap and annular slot design.

Orifice Flange Series: 1. Raised face (RF type) 2. Ring-Joint (RJ type) 3. Slip-on (SO type) 4.Thread type



PADDLE TYPE ORIFICE PLATE

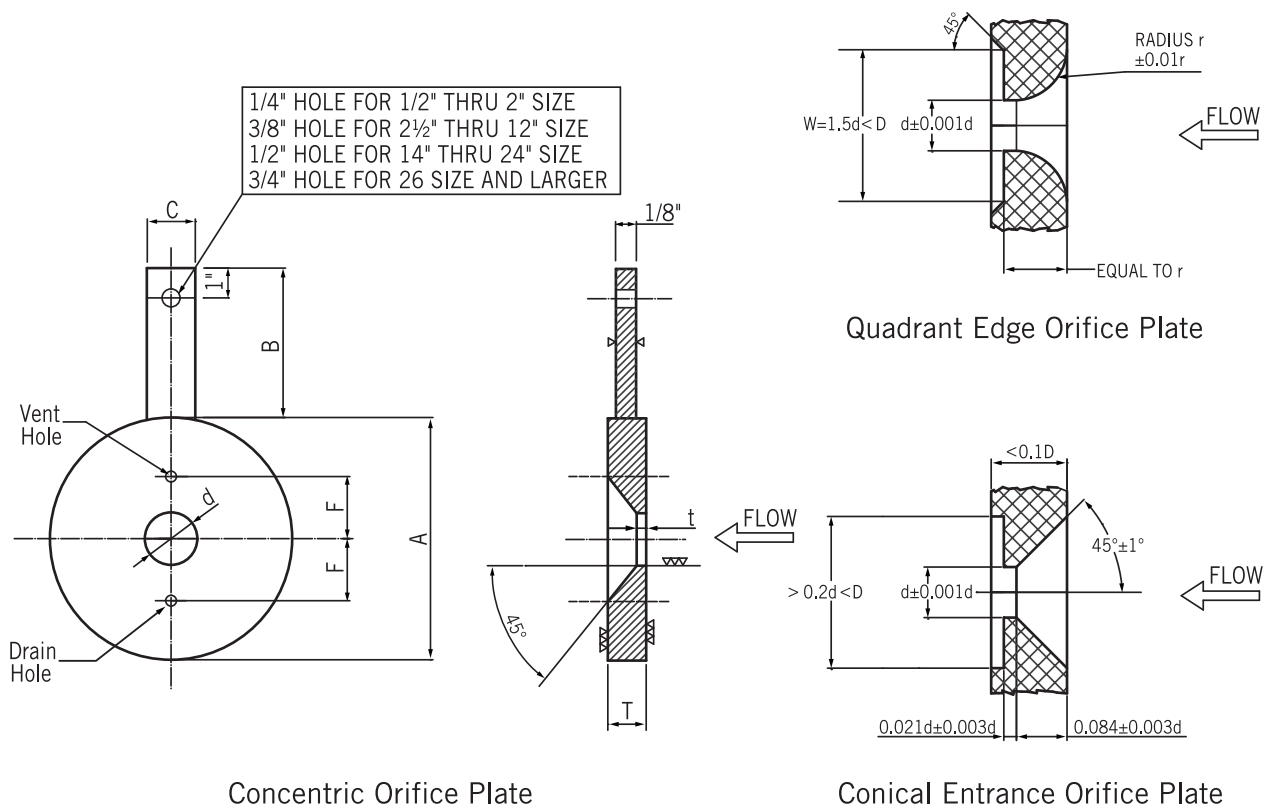

PADDLE TYPE RESTRICTION PLATE

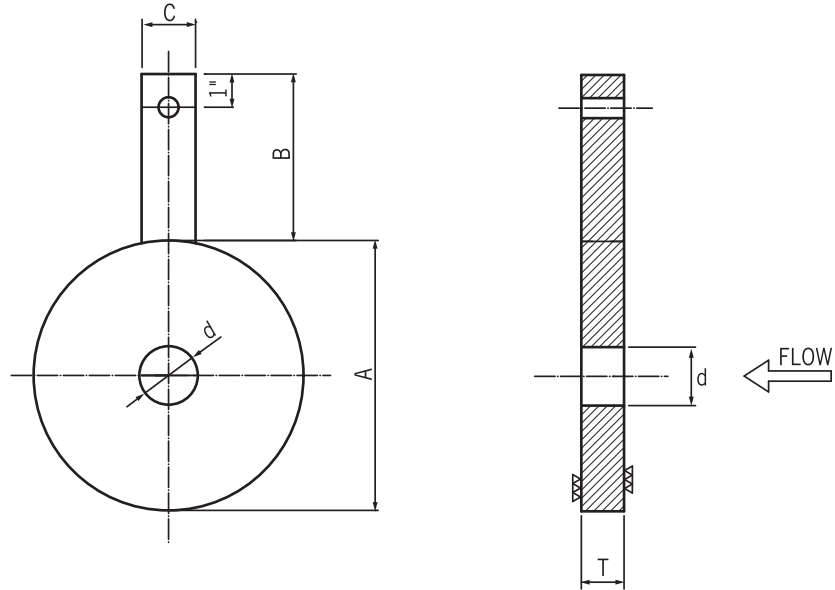

SEGMENTAL ORIFICE PLATE

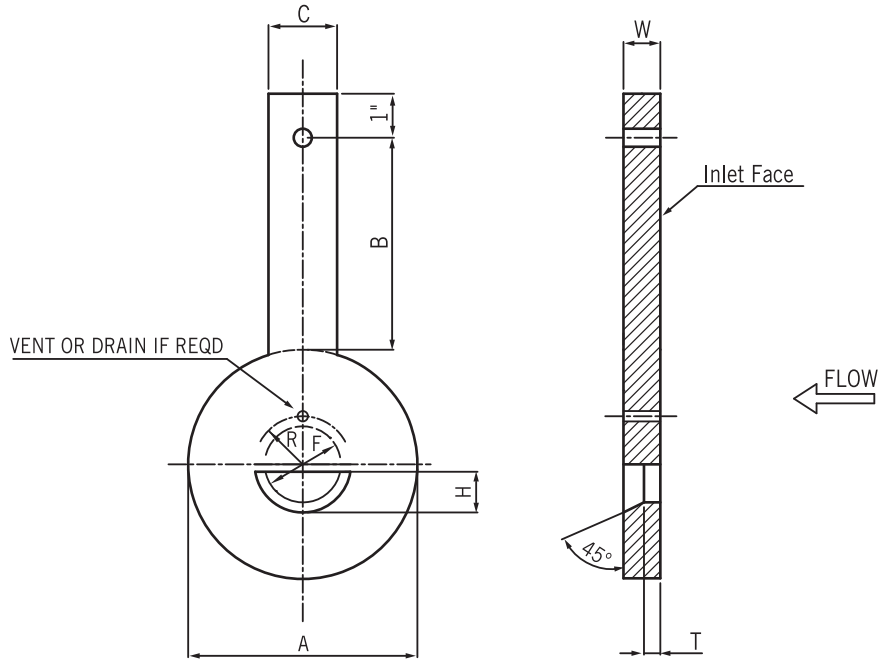

ECCENTRIC PLATE

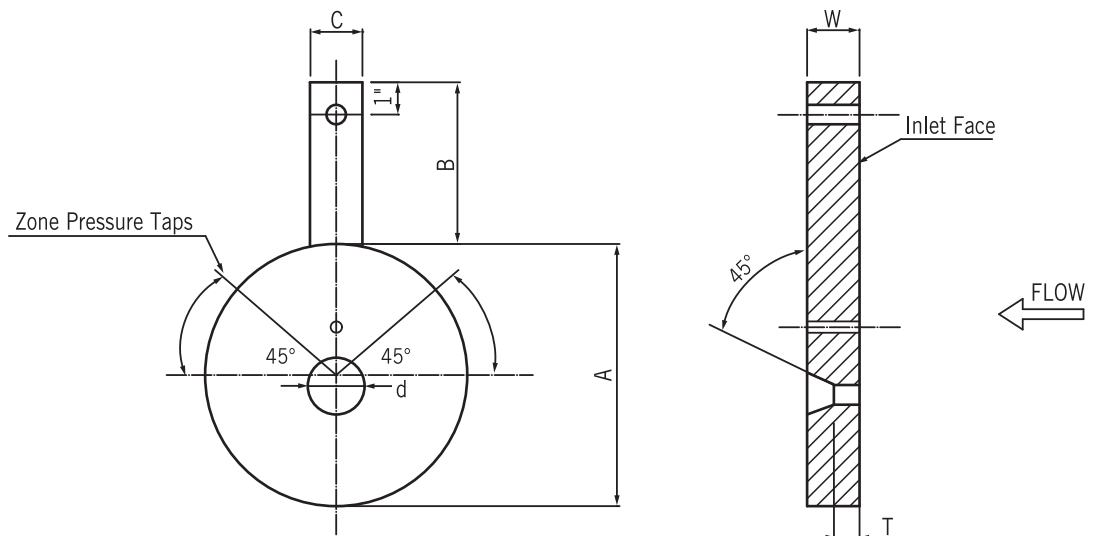

CORNER TYPE PLATE (MODEL: CORNER TAP-1)

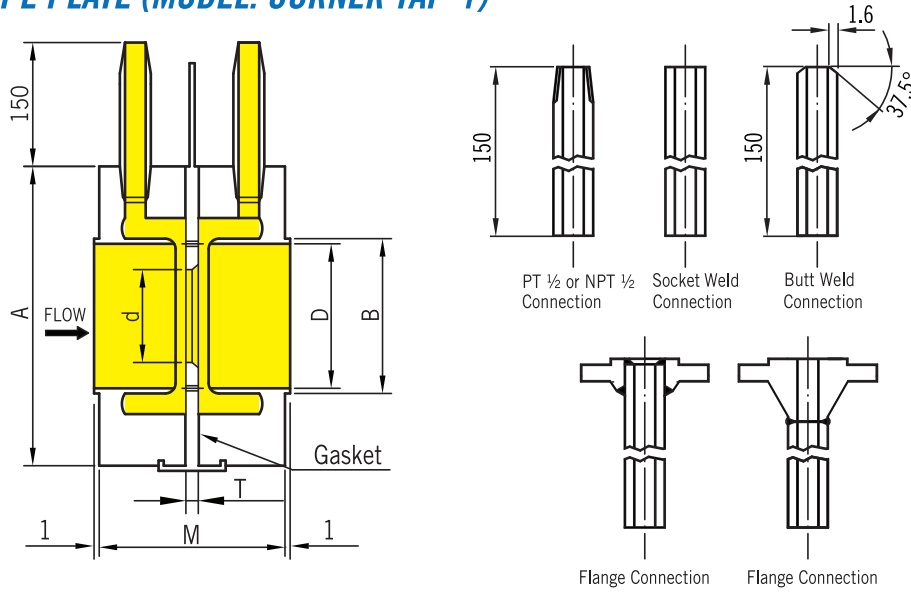

CORNER TYPE PLATE (MODEL: CORNER TAP-2)

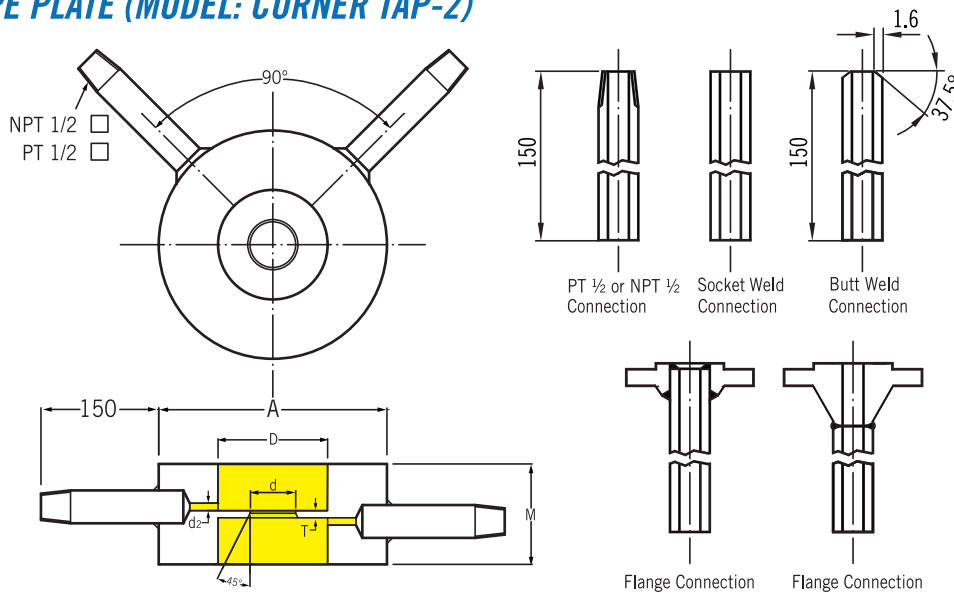

PADDLE TYPE LARGE AND SMALL ECCENTRIC PLATE

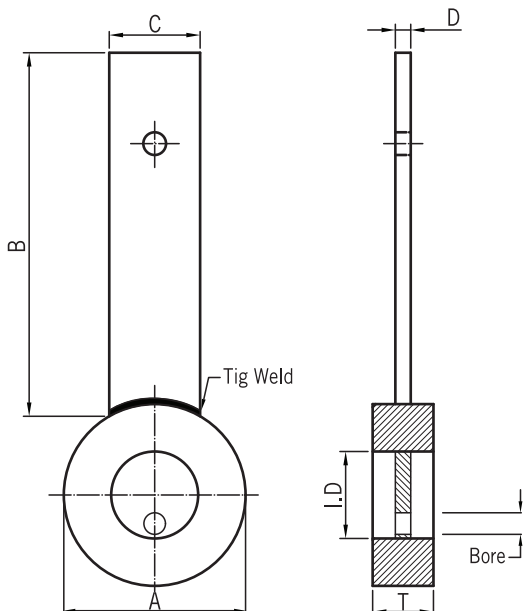

PADDLE TYPE LARGE AND SMALL CONCENTRIC PLATE

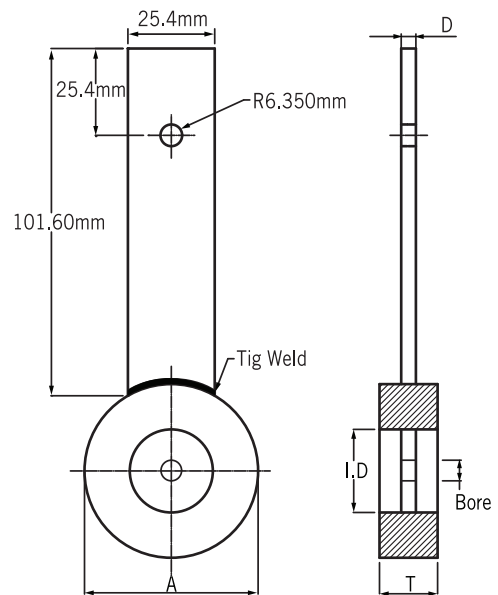

RING-JOINT ORIFICE PALTE

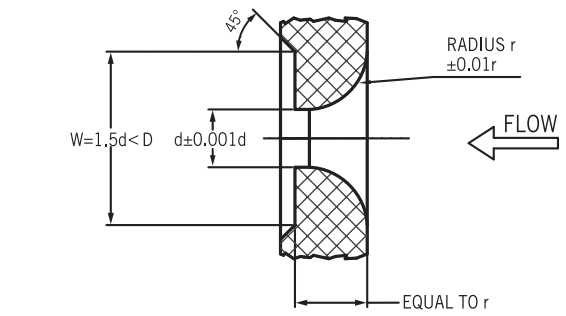
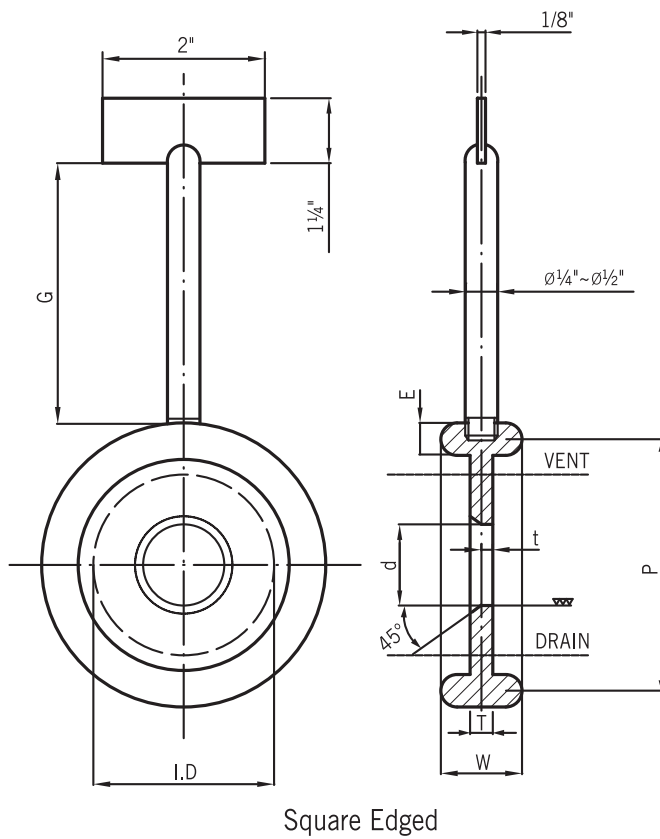

Quadrant Edge Orifice Plate

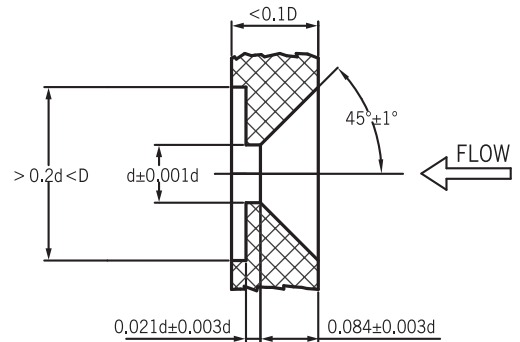

Conical Entrance Orifice Plate

SCREW TYPE RING-JOINT ORIFICE PLATE

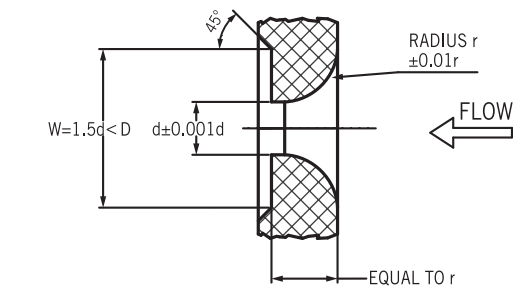
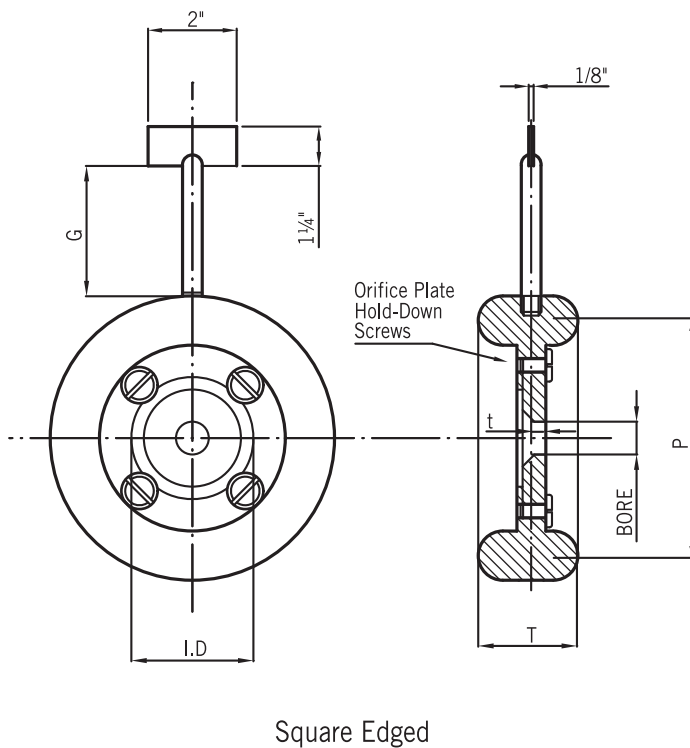

Quadrant Edge Orifice Plate

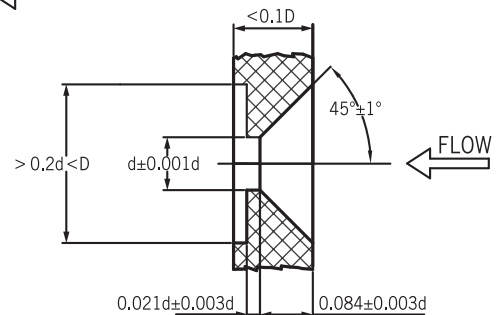

Conical Entrance Orifice Plate

300LB. -400LB. ANSI B16.36 FORGED STEEL WELDING NECK ORIFICE FLANGES

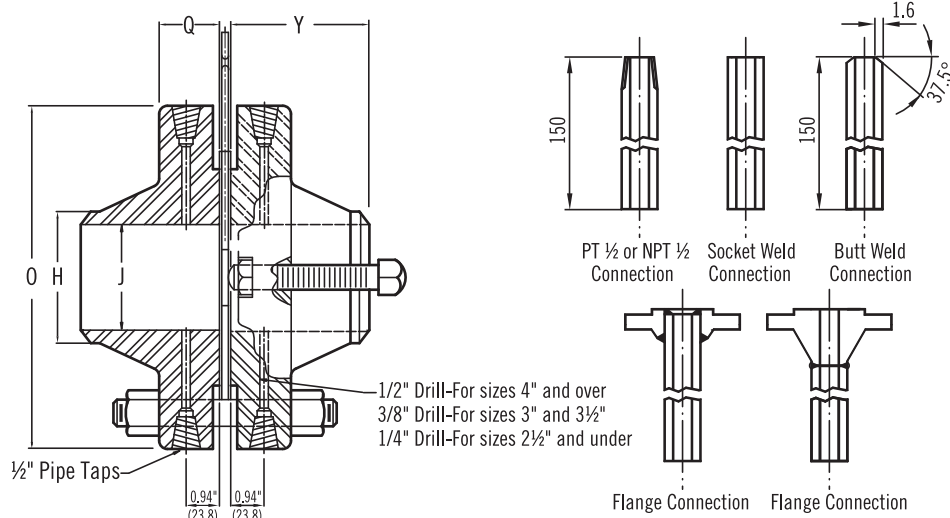

RAISED FACE (RF TYPE)

unit:mm

300 LB.														
NOMINAL PIPE SIZE	OUTSIDE DIAM OF FLANGE	THICKNESS OF FLANGES	DIAM. OF HUB	LENGTH THROUGH HUB	DIAM. OF BORE	DIAM. OF RAISED FACE	DEPTH OF JACK SCREW SLOT	JACK SCREW SIZE	NUMBER OF BOLT HOLES	DIAM. OF HOLES	DIAM. OF BLOTS	LENGTH OF BOLTS	BOLT CIRCLE	APPROX. WEIGHT UNION lb.
		O	Q	H	Y	J								
1	123.8	38.1	33.5	82.6	26.7	71.4	9.5	Two extra carbon steel bolts are furnished to be used as jack screws.	4	19.1	15.9	101.6	88.9	8.2
1 1/2	155.6	38.1	48.3	85.7	40.9	93.7	12.7		4	22.2	19.1	107.9	114.3	11.4
2	165.1	38.1	60.5	85.7	52.6	109.5	9.5		8	19.1	15.9	101.6	127.0	12.2
2 1/2	190.5	38.1	73.2	88.9	62.7	128.6	12.7		8	22.2	19.1	107.9	149.2	15.8
3	209.6	38.1	88.9	88.9	78.0	147.6	12.7		8	22.2	19.1	107.9	168.3	19.5
4	254.0	38.1	114.3	92.7	102.4	179.4	12.7		8	22.2	19.1	107.9	200.0	29.9
6	317.5	38.1	168.4	100.0	154.2	247.7	12.7		12	22.2	19.1	107.9	269.8	48.1
8	381.0	41.1	219.2	111.1	203.0	304.8	15.9		12	25.4	22.2	107.9	330.2	69.0
10	444.5	47.8	273.1	117.5	254.5	358.8	19.1		16	28.6	25.4	139.7	387.4	98.0
12	520.7	50.8	323.9	130.2	304.8	419.1	22.2		16	31.8	28.6	139.7	450.9	148.5
14	584.2	53.8	355.6	142.9	366.6	482.6	22.2		20	31.8	28.6	152.4	514.4	203.3
16	647.7	57.2	406.1	146.1	387.4	536.6	25.4		20	34.9	31.8	165.1	571.5	270.5
18	711.2	60.5	457.2	158.8	438.2	593.7	25.4		24	34.9	31.8	165.1	628.6	336.4
20	774.7	63.5	508.0	161.9	489.0	650.9	25.4		24	34.9	31.8	177.8	685.8	402.6
24	914.4	69.9	609.6	168.3	593.1	771.5	31.8		24	42.3	38.1	190.5	812.8	595.2

400 LB.														
NOMINAL PIPE SIZE	OUTSIDE DIAM OF FLANGE	THICKNESS OF FLANGES	DIAM. OF HUB	LENGTH THROUGH HUB	DIAM. OF BORE	DIAM. OF RAISED FACE	DEPTH OF JACK SCREW SLOT	JACK SCREW SIZE	NUMBER OF BOLT HOLES	DIAM. OF HOLES	DIAM. OF BLOTS	LENGTH OF BOLTS	BOLT CIRCLE	APPROX. WEIGHT UNION lb.
		O	Q	H	Y	J								
1	123.8	44.5	33.5	82.6	To be specified by purchaser.	71.4	9.5	47.6	4	19.1	15.9	120.7	88.9	8.2
1 1/2	155.6	44.5	48.3	85.7		93.7	12.7	57.2	4	22.2	19.1	127.0	114.3	11.4
2	165.1	44.5	60.5	85.7		109.5	9.5	47.6	8	22.2	15.9	120.7	127.0	12.3
2 1/2	191.5	44.5	73.2	88.9		128.6	12.7	57.2	8	22.2	19.1	127.0	149.2	15.9
3	209.6	44.5	88.9	88.9		147.6	12.7	57.2	8	22.2	19.1	127.0	168.3	19.5
4	254.0	44.5	114.3	88.9		157.2	6.4	57.2	8	25.4	22.2	139.7	200.0	37.2
6	317.5	47.5	168.4	103.2		215.9	12.7	88.9	12	25.4	22.2	158.8	269.9	61.7
8	381.0	54.1	219.2	117.5		269.5	12.7	88.9	12	28.6	25.4	171.5	330.2	96.7
10	444.5	60.2	273.1	123.8		323.9	12.7	101.6	16	31.8	28.6	193.7	387.4	140.3
12	520.7	63.5	323.9	136.5		381.0	12.7	101.6	16	34.9	31.8	203.2	450.9	194.8
14	584.2	67.1	355.6	149.2		412.8	12.7	108.3	20	34.9	31.8	209.6	514.4	251.5
16	647.7	69.9	406.0	152.4		469.9	12.7	108.3	20	38.1	34.9	222.3	571.5	320.0
18	711.2	72.9	457.2	165.1		533.4	12.7	44.3	24	38.1	34.9	234.9	628.7	391.8
20	774.7	76.2	508.0	168.3		584.2	12.7	120.7	24	41.3	38.1	247.7	685.8	483.9
24	914.4	82.6	609.6	174.6		692.2	12.7	127.0	24	47.6	44.5	279.4	812.8	706.0

600LB. -1500LB. ANSI B16.36 FORGED STEEL WELDING NECK ORIFICE FLANGES RAISED FACE (RF TYPE)

600 LB.														
NOMINAL PIPE SIZE	OUTSIDE DIAM OF FLANGE	THICKNESS OF FLANGES	DIAM. OF HUB	LENGTH THROUGH HUB	DIAM. OF BORE	DIAM. OF RAISED FACE	DEPTH OF JACK SCREW SLOT	JACK SCREW SIZE	NUMBER OF BOLT HOLES	DIAM. OF BOLT HOLES	DIAM. OF STUD BLOTS	LENGTH OF STUD BOLTS	BOLT CIRCLE	APPROX. WEIGHT UNION lb.
							RAISED FACE					RAISED FACE		
		0	Q	H			Y					J		
1	123.8	44.5	33.5	82.6	To be specified by purchaser.	71.4	9.5	47.6	4	17.5	15.9	120.7	88.9	8.2
1½	155.6	44.5	48.3	85.7		93.7	12.7	57.2	4	20.6	19.1	127.0	114.3	11.4
2	165.1	44.5	60.5	85.7		109.5	9.5	47.6	8	17.5	15.9	120.7	127.0	12.3
2½	190.5	44.5	73.2	88.9		128.6	12.7	57.2	8	20.6	19.1	127.0	149.2	15.9
3	209.6	44.5	88.9	88.9		147.6	12.7	57.2	8	20.6	19.1	127.0	168.3	19.5
4	273.1	44.5	114.3	101.6		157.2	6.4	57.2	8	25.4	22.2	146.1	215.9	46.8
6	355.6	54.1	168.4	117.5		215.9	12.7	88.9	12	28.6	25.4	171.5	292.1	88.5
8	419.1	62.0	219.2	133.3		269.9	12.7	101.6	12	108.0	28.6	193.7	349.3	126.2
10	508.0	69.9	273.1	152.4		323.9	12.7	101.6	16	34.9	31.8	215.9	431.8	206.1
12	558.8	72.9	233.9	155.6		381.0	12.7	114.3	20	34.9	31.8	228.6	489.0	251.1
14	603.3	76.2	355.6	165.1		412.8	12.7	127.0	20	38.1	34.9	235.0	527.1	370.0
16	685.8	82.6	406.4	177.8		469.9	12.7	127.0	20	41.3	38.1	254.0	603.3	505.3
18	743.0	88.9	457.2	184.2		533.4	12.7	127.0	20	44.5	41.3	279.4	654.1	592.9
20	813.8	95.3	508.0	190.5		584.2	12.7	152.4	24	44.5	41.3	298.5	723.9	612.9
24	939.8	108.0	609.6	203.2		692.2	12.7	152.4	24	50.8	47.6	336.6	838.2	1044.2

900 LB. (for sizes 2-1/2 inch and smaller, use 1500LB.)														
NOMINAL PIPE SIZE	OUTSIDE DIAM OF FLANGE	THICKNESS OF FLANGES	DIAM. OF HUB	LENGTH THROUGH HUB	DIAM. OF BORE	DIAM. OF RAISED FACE	DEPTH OF JACK SCREW SLOT	JACK SCREW SIZE	NUMBER OF BOLT HOLES	DIAM. OF BOLT HOLES	DIAM. OF STUD BLOTS	LENGTH OF STUD BOLTS	BOLT CIRCLE	APPROX. WEIGHT UNION lb.
							RAISED FACE					RAISED FACE		
		0	Q	H			Y					J		
3	241.3	44.5	88.9	101.6	To be specified by purchaser.	127.0	9.5	88.9	8	25.4	22.2	146.1	190.5	35.9
4	292.1	50.8	114.3	114.3		157.2	9.5	88.9	8	31.8	26.5	177.8	235.0	58.6
6	381.0	62.0	168.4	139.7		215.9	15.9	114.3	12	31.8	28.6	193.7	317.5	119.4
8	469.9	69.9	219.2	161.9		269.9	15.9	114.3	12	38.1	34.9	228.6	393.7	202.0
10	546.1	76.2	273.1	184.2		323.9	15.9	114.3	16	38.1	34.9	235.0	469.9	287.8
12	609.1	85.6	323.9	200.0		381.0	15.9	114.3	20	38.1	34.9	254.0	533.4	395.9

1500 LB.														
NOMINAL PIPE SIZE	OUTSIDE DIAM OF FLANGE	THICKNESS OF FLANGES	DIAM. OF HUB	LENGTH THROUGH HUB	DIAM. OF BORE	DIAM. OF RAISED FACE	DEPTH OF JACK SCREW SLOT	JACK SCREW SIZE	NUMBER OF BOLT HOLES	DIAM. OF BOLT HOLES	DIAM. OF STUD BLOTS	LENGTH OF STUD BOLTS	BOLT CIRCLE	APPROX. WEIGHT UNION lb.
							RAISED FACE					RAISED FACE		
		0	Q	H			Y					J		
1	149.2	44.5	33.5	73.1	To be specified by purchaser.	50.8	6.4	76.2	4	25.4	22.2	139.7	101.6	11.8
1½	177.8	44.5	48.3	82.6		73.1	6.4	76.2	4	28.6	25.4	146.1	123.8	20.4
2	215.9	44.5	60.5	101.6		92.1	6.4	76.2	8	25.4	22.2	146.1	165.1	29.5
2½	244.5	47.5	73.2	104.8		104.8	6.4	76.2	8	28.6	25.4	158.8	190.5	44.5
3	266.7	54.1	88.9	117.5		127.0	9.6	114.3	8	31.8	28.6	177.8	203.2	55.8
4	311.2	60.2	114.3	123.8		157.2	9.6	114.3	8	34.9	31.8	196.9	241.3	82.6
6	393.7	88.9	168.4	171.5		215.9	15.9	165.1	12	38.1	34.9	260.4	317.5	184.8
8	482.6	98.3	219.2	212.7		269.9	15.9	165.1	12	44.5	41.3	292.1	393.7	306.5
10	584.2	114.3	273.1	254.0		323.9	15.9	165.1	12	50.8	47.6	336.6	482.6	498.9
12	673.1	130.3	323.9	282.6		381.0	15.9	165.1	16	54.0	50.8	374.7	571.5	774.5
14	749.3	139.7	355.6	298.5		412.8	15.9	170.0	16	60.5	57.2	412.8	635.0	973.0
16	825.5	152.5	406.4	311.2		469.9	15.9	185.0	16	66.7	63.5	450.9	704.9	1260
18	914.4	168.4	457.2	327.2		533.4	15.9	198.5	16	73.0	71.1	489.0	774.7	1695
20	984.3	184.2	508.0	355.6		584.2	15.9	215.0	16	79.4	76.2	546.1	831.9	2064
24	1168.4	209.4	609.6	406.4		692.2	15.9	240.0	16	92.1	88.9	622.3	990.6	3305

300LB. -400LB. ANSI B16.36 FORGED STEEL WELDING NECK ORIFICE FLANGES

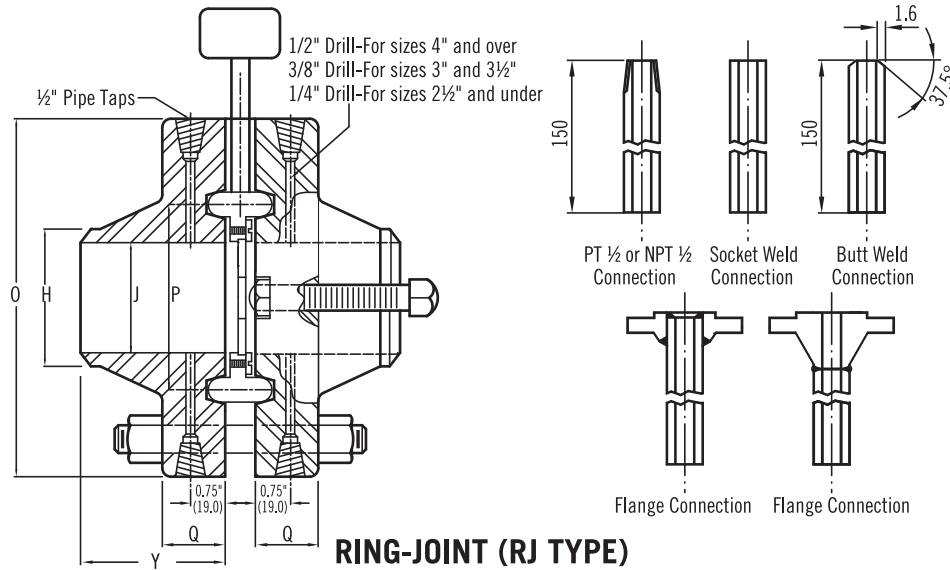

unit:mm

300 LB.

NOMINAL PIPE SIZE	OUTSIDE DIAM OF FLANGE	THICKNESS OF FLANGES RING JOINT	DIAM. OF HUB	LENGTH THROUGH HUB		DIAM. OF BORE	DIAM. OF PITCH	DEPTH OF JACK SCREW SLOT RING JOINT	JACK SCREW SIZE	NUMBER OF BOLT HOLES	DIAM. OF HOLES	DIAM. OF BLOTS	LENGTH OF BOLTS RING JOINT	BOLT CIRCLE	APPROX. WEIGHT UNION lb.
				RING JOINT	RING JOINT										
	O	Q	H	Y	J	P									
1	123.8	38.1	33.5	76.2	26.7	50.8	6.4	Two extra carbon steel bolts are furnished to be used as jack screws.	4	27.0	15.9	120.7	88.9	6.8	
1 1/2	155.6	38.1	48.3	79.4	40.9	68.3	6.4		4	30.2	19.1	127.0	114.3	11.4	
2	165.1	38.1	60.5	79.4	52.6	82.6	6.4		8	27.0	15.9	120.7	127.0	13.6	
2 1/2	190.5	38.1	73.2	82.6	62.7	101.6	6.4		8	30.2	19.1	127.0	149.2	20.8	
3	209.6	38.1	88.9	82.6	78.0	123.8	6.4		8	30.2	19.1	127.0	168.3	25.4	
4	254.0	38.1	114.3	85.7	102.4	149.2	6.4		8	30.2	19.1	127.0	200.0	29.5	
6	317.5	38.1	168.4	98.4	154.2	134.9	6.4		12	22.2	19.1	139.7	269.8	48.6	
8	381.0	41.1	219.2	111.1	203.0	269.9	9.5		12	25.4	22.2	152.4	330.2	76.7	
10	444.5	47.8	273.1	117.5	254.5	323.9	12.7		16	28.6	25.4	165.1	387.4	113.5	
12	520.7	50.8	323.9	130.2	304.8	381.0	15.9		16	31.8	28.6	177.8	450.9	165.7	
14	584.2	53.8	355.6	142.9	366.6	419.1	15.9		20	31.8	28.6	177.8	514.4	222.4	
16	647.7	57.2	406.1	146.1	387.4	469.9	19.1		20	34.9	31.8	203.2	571.5	290.6	
18	711.2	60.5	457.2	158.8	438.2	533.0	19.1		24	34.9	31.8	203.2	628.6	356.4	
20	774.7	63.5	508.0	161.9	489.0	584.2	19.1		24	34.9	31.8	203.2	685.8	435.8	
24	914.4	69.9	609.6	168.3	593.1	692.2	25.4		24	42.3	38.1	228.6	812.8	640.1	

400 LB.

NOMINAL PIPE SIZE	OUTSIDE DIAM OF FLANGE	THICKNESS OF FLANGES RING JOINT	DIAM. OF HUB	LENGTH THROUGH HUB		DIAM. OF BORE	DIAM. OF PITCH	DEPTH OF JACK SCREW SLOT RING JOINT	JACK SCREW SIZE	NUMBER OF BOLT	DIAM. OF HOLES	DIAM. OF BLOTS	LENGTH OF BOLTS RING JOINT	BOLT CIRCLE	APPROX. WEIGHT UNION lb.
				RING JOINT	RING JOINT										
	O	Q	H	Y	J	P									
1	123.8	44.5	33.5	82.6	To be specified by purchaser.	50.8	6.4	63.5	4	27.0	15.9	133.4	88.9	6.8	
1 1/2	155.6	44.5	48.3	85.7		68.3	6.4	76.2	4	30.2	19.1	139.7	114.3	11.4	
2	165.1	46.0	60.5	85.7		82.6	6.4	63.5	8	30.2	15.9	133.4	127.0	13.6	
2 1/2	191.5	46.0	73.2	88.9		101.6	6.4	76.2	8	30.2	19.1	139.7	149.2	20.9	
3	209.6	46.0	88.9	88.9		123.8	6.4	76.2	8	30.2	19.1	139.7	168.3	25.4	
4	254.0	46.0	114.3	88.9		149.2	15.9	76.2	8	30.2	22.2	152.4	200.0	40.9	
6	317.5	49.1	168.4	103.2		134.9	22.2	101.6	12	25.4	22.2	165.1	269.9	65.8	
8	381.0	55.7	219.2	117.5		269.9	22.2	114.3	12	28.6	25.4	184.2	330.2	99.9	
10	444.5	61.8	273.1	123.8		323.9	22.2	114.3	16	31.8	28.6	203.2	387.4	147.6	
12	520.7	65.1	323.9	136.5		381.0	22.2	127.0	16	34.9	31.8	215.9	450.9	204.3	
14	584.2	68.6	355.6	149.2		419.1	22.2	127.0	20	34.9	31.8	228.6	514.4	267.9	
16	647.7	71.4	406.0	152.4		469.9	22.2	127.0	20	38.1	34.9	234.9	571.5	338.2	
18	711.2	74.5	457.2	165.1		533.0	22.2	127.0	24	38.1	34.9	241.3	628.7	413.1	
20	774.7	79.4	508.0	168.3		584.2	22.2	139.7	24	41.3	38.1	260.4	685.8	526.6	
24	914.4	87.3	609.6	174.6		690.2	22.2	152.0	24	47.6	44.5	285.8	812.8	755.9	

600LB. -1500LB. ANSI B16.36 FORGED STEEL WELDING NECK ORIFICE FLANGES RING-JOINT (RJ TYPE)

unit:mm

600 LB.																			
NOMINAL PIPE SIZE	OUTSIDE DIAM OF FLANGE	THICKNESS OF FLANGES		DIAM. OF HUB		LENGTH THROUGH HUB RING JOINT	DIAM. OF BORE	DIAM. OF PITCH	DEPTH OF JACK SCREW SLOT		JACK SCREW SIZE	NUMBER OF BOLT HOLES	DIAM. OF BOLT HOLES	DIAM. OF STUD BLOTS	LENGTH OF STUD BOLTS		BOLT CIRCLE	APPROX. WEIGHT UNION lb.	
		RING JOINT	H	Y	J				P	RING JOINT					RING JOINT	RING JOINT		RING JOINT	RING JOINT
1	123.8	44.5	33.5	76.2	To be specified by purchaser.	50.8	12.7	55.6	4	19.1	15.9	133.4	88.9	6.8					
1½	155.6	44.5	48.3	79.4		68.3	12.7	55.6	4	22.2	19.1	139.7	114.3	11.4					
2	165.1	46.0	60.5	79.4		82.6	12.7	63.5	8	19.1	15.9	133.4	127.0	13.6					
2½	190.5	46.0	73.2	82.6		101.6	12.7	63.5	8	22.2	19.1	139.7	149.2	20.9					
3	209.6	46.0	88.9	82.6		123.8	15.9	76.2	8	22.2	19.1	139.7	168.3	25.4					
4	273.1	46.0	114.3	101.6		149.2	15.9	76.2	8	25.4	22.2	158.8	215.9	44.9					
6	355.6	55.7	168.4	117.5		211.1	22.2	114.3	12	28.6	25.4	184.2	292.1	89.4					
8	419.1	63.6	219.2	133.3		269.9	22.2	120.7	12	108.0	28.6	209.6	349.3	128.9					
10	508.0	71.4	273.1	152.4		323.9	22.2	127.0	16	34.9	31.8	228.6	431.8	214.3					
12	558.8	74.5	233.9	155.6		381.0	22.2	127.0	20	34.9	31.8	235.0	489.0	259.2					
14	603.3	77.8	355.6	165.1		419.1	22.2	139.7	20	38.1	34.9	247.7	527.1	377.0					
16	685.8	84.1	406.4	177.8		469.9	22.2	139.7	20	41.3	38.1	266.7	603.3	515.3					
18	743.0	90.5	457.2	184.2		533.4	22.2	146.1	20	44.5	41.3	285.8	654.1	603.8					
20	813.8	98.4	508.0	190.5		584.2	22.2	158.8	24	44.5	41.3	304.8	723.9	631.1					
24	939.8	112.7	609.6	203.2		692.2	22.2	177.8	24	50.8	47.6	342.9	838.2	1078.3					

900 LB. (for sizes 2-1/2 inch and smaller, use 1500LB.)																			
NOMINAL PIPE SIZE	OUTSIDE DIAM OF FLANGE	THICKNESS OF FLANGES		DIAM. OF HUB		LENGTH THROUGH HUB RING JOINT	DIAM. OF BORE	DIAM. OF PITCH	DEPTH OF JACK SCREW SLOT		JACK SCREW SIZE	NUMBER OF BOLT HOLES	DIAM. OF BOLT HOLES	DIAM. OF STUD BLOTS	LENGTH OF STUD BOLTS		BOLT CIRCLE	APPROX. WEIGHT UNION lb.	
		RING JOINT	H	Y	J				P	RING JOINT					RING JOINT	RING JOINT		RING JOINT	
																			0
3	241.3	46.0	88.9	101.6	To be specified by purchaser.	123.8	15.9	120.7	8	25.4	22.2	158.8	190.5	38.6					
4	292.1	52.4	114.3	114.3		149.2	15.9	85.7	8	31.8	26.5	184.2	235.0	63.6					
6	381.0	63.6	168.4	139.7		211.1	22.2	120.7	12	31.8	28.6	209.6	317.5	127.1					
8	469.9	71.4	219.2	161.9		269.9	22.2	127.0	12	38.1	34.9	235.0	393.7	215.7					
10	546.1	77.8	273.1	184.2		323.9	22.2	133.3	16	38.1	34.9	247.7	469.9	306.5					
12	609.1	87.2	323.9	200.0		381.0	22.2	139.7	20	38.1	34.9	273.1	533.4	422.2					

1500 LB.																			
NOMINAL PIPE SIZE	OUTSIDE DIAM OF FLANGE	THICKNESS OF FLANGES		DIAM. OF HUB		LENGTH THROUGH HUB RING JOINT	DIAM. OF BORE	DIAM. OF PITCH	DEPTH OF JACK SCREW SLOT		JACK SCREW SIZE	NUMBER OF BOLT HOLES	DIAM. OF BOLT HOLES	DIAM. OF STUD BLOTS	LENGTH OF STUD BOLTS		BOLT CIRCLE	APPROX. WEIGHT UNION lb.	
		RING JOINT	H	Y	J				P	RING JOINT					RING JOINT	RING JOINT		RING JOINT	
																			0
1	149.2	44.5	33.5	76.2	To be specified by purchaser.	50.8	12.7	55.6	4	25.4	22.2	146.1	101.6	12.3					
1½	177.8	44.5	48.3	82.6		68.3	12.7	55.6	4	28.6	25.4	152.4	123.8	18.6					
2	215.9	46.0	60.5	101.6		95.3	12.7	63.5	8	25.4	22.2	158.8	165.1	32.2					
2½	244.5	49.1	73.2	104.8		108.0	12.7	63.5	8	28.6	25.4	171.5	190.5	45.4					
3	266.7	55.7	88.9	117.5		127.0	15.9	85.7	8	31.8	28.6	193.7	203.2	59.5					
4	311.2	61.8	114.3	123.8		157.2	15.9	85.7	8	34.9	31.8	209.6	241.3	90.8					
6	393.7	92.1	168.4	171.5		215.9	22.2	152.4	12	38.1	34.9	279.4	317.5	197.5					
8	482.6	103.1	219.2	212.7		269.9	22.2	165.1	12	44.5	41.3	317.5	393.7	324.6					
10	584.2	119.1	273.1	254.0		323.9	22.2	177.8	12	50.8	47.6	362.0	482.6	528.9					
12	673.1	138.2	323.9	282.6		381.0	22.2	203.2	16	54.0	50.8	406.4	571.5	812.7					

300LB. -1500LB. ANSI B16.36 FORGED STEEL SLIP-ON ORIFICE FLANGES

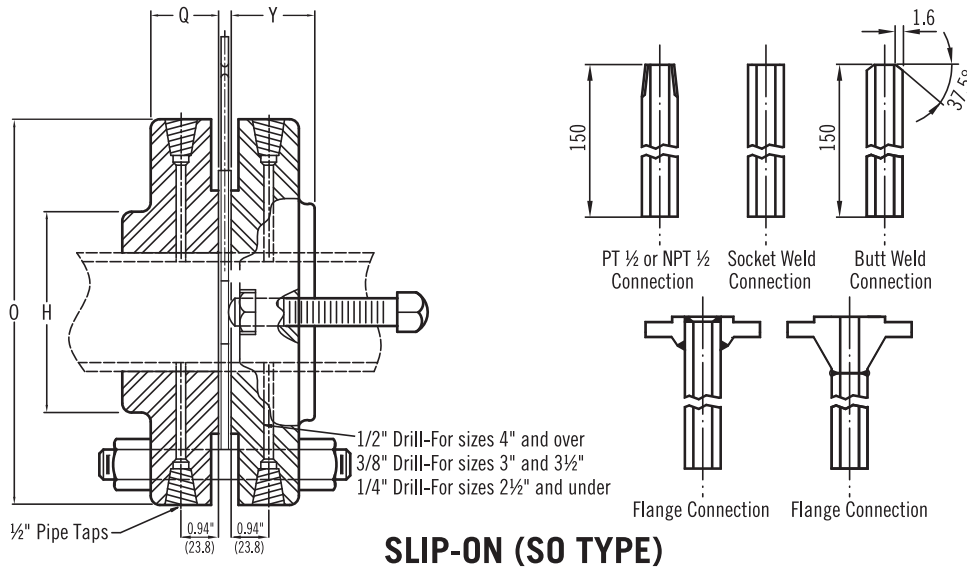

300 LB.															
NOMINAL PIPE SIZE	OUTSIDE DIAM OF FLANGE	THICKNESS OF FLANGES	DIAM. OF HUB	LENGTH THROUGH HUB	DIAM. OF RAISED FACE	DIAM. OF BORE	HEIGHT TO COUNTER BORE	FACE COUNTER BORE HEIGHT	DEPTH OF JACK SCREW SLOT	NUMBER OF BOLT HOLES	DIAM. OF BOLT HOLES	DIAM. OF BLOTS	LENGTH OF BOLTS	BOLT CIRCLE	APPROX. WEIGHT UNIT lb.
					SLIP-ON										
	O	Q	H	Y		F	G								
1	123.8	38.1	54.0	47.6	71.4	34.5	38.1	20.6	9.5	4	17.5	15.9	101.6	88.9	6.8
1½	155.6	38.1	44.5	47.6	93.7	49.5	38.1	15.9	12.7	4	20.6	19.1	108.0	114.3	8.6
2	165.1	38.1	84.1	49.2	109.5	62.0	38.1	12.7	9.5	8	17.5	15.9	101.6	127.0	10.4
2½	190.5	38.1	100.0	50.8	128.6	76.7	44.5	15.9	12.7	8	20.6	19.1	108.0	149.2	14.1
3	210.0	38.1	117.5	52.4	147.6	90.7	44.5	12.7	12.7	8	20.6	19.1	108.0	168.3	17.7
4	254.0	38.1	146.1	54.0	179.4	116.1	44.5	11.1	12.7	8	20.6	19.1	108.0	200.0	27.2
6	317.5	38.1	206.4	54.0	247.7	170.7	44.5	6.4	12.7	12	22.2	19.1	108.0	270.0	45.4
8	381.0	41.1	260.4	61.9	304.8	221.5	50.8	-	15.9	12	25.4	22.2	114.3	330.2	60.8
10	444.5	47.8	320.7	66.7	358.8	276.4	55.6	-	19.1	16	28.6	25.4	139.7	387.4	89.0
12	520.7	50.8	374.7	73.0	419.1	327.2	60.3	-	22.2	16	31.8	28.6	139.7	450.9	128.0
14	584.2	53.8	425.5	76.2	482.6	359.2	63.5	-	22.2	20	31.8	28.6	152.4	514.4	172.5
16	647.7	57.2	482.6	82.6	536.6	410.5	68.3	-	25.4	20	34.9	31.8	165.1	571.5	281.5
18	711.2	60.5	533.4	88.9	593.7	461.8	69.9	-	25.4	24	34.9	31.8	165.1	628.6	313.7
20	774.7	63.5	587.4	95.3	650.9	513.1	73.0	-	25.4	24	34.9	31.8	177.8	685.8	354.6
24	914.4	69.9	701.7	106.4	692.2	616.0	82.6	-	31.8	24	41.3	38.1	190.5	812.8	545.3

400 LB. (sizes 3 inch and smaller furnished same as 300LB. except with stud bolts long enough for extra nut.)															
NOMINAL PIPE SIZE	OUTSIDE DIAM OF FLANGE	THICKNESS OF FLANGES	DIAM. OF HUB	LENGTH THROUGH HUB	HEIGHT TO COUNTER BORE	DIAM. OF TO RAISED FACE	DEPTH OF JACK SCREW SLOT	JACK SCREW SIZE	NUMBER OF BOLT HOLES	DIAM. OF BOLT HOLES	DIAM. OF BLOTS	LENGTH OF BOLTS STUD	BOLT CIRCLE	APPROX. WEIGHT UNIT lb.	
															O
4	254.0	44.5	146.1	50.8	42.9	157.2	6.4	19.1x76.2	203.2	25.4	22.2	139.7	200.0	29.0	
6	317.5	47.5	206.4	57.2	52.4	215.9	9.5	25.4x88.9	304.8	25.4	22.2	158.8	269.9	50.0	
8	381.0	54.1	260.4	68.3	57.2	269.9	9.5	25.4x88.9	304.8	28.6	25.4	171.5	330.2	76.7	
10	444.5	60.2	320.7	73.0	61.9	323.9	12.7	25.4x101.6	406.4	31.8	28.6	193.7	387.4	108.5	
12	520.7	63.5	374.7	79.4	66.7	381.0	15.9	25.4x101.6	406.4	34.9	31.8	203.2	450.9	151.2	

600 LB. (sizes 3 inch and smaller furnished same as 300LB. except with stud bolts long enough for extra nut.)															
NOMINAL PIPE SIZE	OUTSIDE DIAM OF FLANGE	THICKNESS OF FLANGES	DIAM. OF HUB	LENGTH THROUGH HUB	HEIGHT TO COUNTER BORE	DIAM. OF TO RAISED FACE	DEPTH OF JACK SCREW SLOT	JACK SCREW SIZE	NUMBER OF BOLT HOLES	DIAM. OF BOLT HOLES	DIAM. OF BLOTS STUD	LENGTH OF BOLTS STUD	BOLT CIRCLE	APPROX. WEIGHT UNIT lb.	
															O
4	273.1	44.5	152.4	54.0	47.6	157.2	6.4	19.1x76.2	8	25.4	22.2	146.1	215.9	40.4	
6	355.6	54.1	222.3	66.7	57.2	215.9	12.7	25.4x88.9	12	28.6	25.4	171.5	292.1	87.6	
8	419.1	62.0	273.1	76.2	63.5	269.9	12.7	25.4x101.6	12	31.8	28.6	193.7	349.3	124.4	
10	508.0	69.9	342.9	85.7	71.4	323.9	12.7	25.4x101.6	16	34.9	31.8	215.9	431.8	195.0	
12	558.8	72.9	400.1	92.1	76.2	381.0	12.7	25.4x114.3	20	34.9	31.8	228.6	489.0	241.1	

900 LB.

NOMINAL PIPE SIZE	OUTSIDE DIAM OF FLANGE	THICKNESS OF FLANGES	DIAM. OF HUB	LENGTH THROUGH HUB	HEIGHT TO COUNTER BORE	DIAM. OF TO RAISED FACE	DEPTH OF JACK SCREW SLOT	JACK SCREW SIZE	NUMBER OF BOLT HOLES	DIAM. OF BOLT HOLES	DIAM. OF BLOTS STUD	LENGTH OF BOLTS STUD	BOLT CIRCLE	APPROX. WEIGHT UNIT lb.
	O	Q	H	Y	F									
3	241.3	44.5	127.0	54.0	47.6	127.0	6.4	19.1x88.9	8	25.4	22.2	146.1	190.0	35.0
4	292.1	50.8	158.8	69.9	54.0	157.2	6.4	19.1x88.9	8	31.8	28.6	177.8	235.0	60.4
6	381.0	62.0	235.0	85.7	63.5	215.9	12.7	25.4x114.3	12	31.8	28.6	193.7	317.5	117.6
8	469.9	69.9	298.5	101.6	69.9	269.9	12.7	25.4x114.3	12	38.1	34.9	228.6	393.7	188.4
10	546.1	76.2	368.3	108.0	77.8	323.9	12.7	25.4x114.3	16	38.1	34.9	235.0	470.0	267.0
12	609.6	85.6	419.1	117.5	82.6	381.0	12.7	25.4x114.3	20	38.1	34.9	254.0	533.4	354.0

1500 LB.

NOMINAL PIPE SIZE	OUTSIDE DIAM OF FLANGE	THICKNESS OF FLANGES	DIAM. OF HUB	LENGTH THROUGH HUB	HEIGHT TO COUNTER BORE	DIAM. OF TO RAISED FACE	DEPTH OF JACK SCREW SLOT	JACK SCREW SIZE	NUMBER OF BOLT HOLES	DIAM. OF BOLT HOLES	DIAM. OF BLOTS STUD	LENGTH OF BOLTS STUD	BOLT CIRCLE	APPROX. WEIGHT UNIT lb.
	O	Q	H	Y	F									
1	149.2	44.5	52.4	47.6	38.1	50.8	6.4	15.9x76.2	4	25.4	22.2	139.7	101.6	11.8
1½	177.8	44.5	69.9	47.6	38.1	73.0	6.4	15.9x76.2	4	28.6	25.4	146.1	123.8	20.4
2	215.9	44.5	104.8	57.2	44.5	92.1	6.4	15.9x76.2	8	25.4	22.2	146.1	165.1	29.5
2½	244.5	47.5	123.8	63.5	54.0	104.8	6.4	15.9x76.2	8	28.6	25.4	158.6	190.5	44.5
3	266.7	54.1	133.4	73.0	57.2	127.0	6.4	19.1x114.3	8	31.8	28.6	177.8	203.2	55.8
4	311.2	60.2	161.9	90.5	63.5	157.2	6.4	19.1x114.3	8	34.9	31.8	196.9	241.3	82.6
6	393.7	88.9	228.6	119.1	76.2	215.9	12.7	25.4x165.1	12	38.1	34.9	260.4	317.5	184.8
8	482.6	98.3	292.1	142.9	82.6	269.9	12.7	25.4x165.1	12	44.5	34.9	292.1	393.7	292.8
10	584.2	114.3	368.3	158.8	90.5	323.9	12.7	25.4x165.1	12	50.8	47.6	336.6	482.6	482.6
12	673.1	130.3	450.9	181.0	98.4	381.0	12.7	25.4x165.1	16	54.0	50.8	374.7	571.5	753.6

300LB. ANSI B16.36 FORGED STEEL THREAD ORIFICE FLANGES

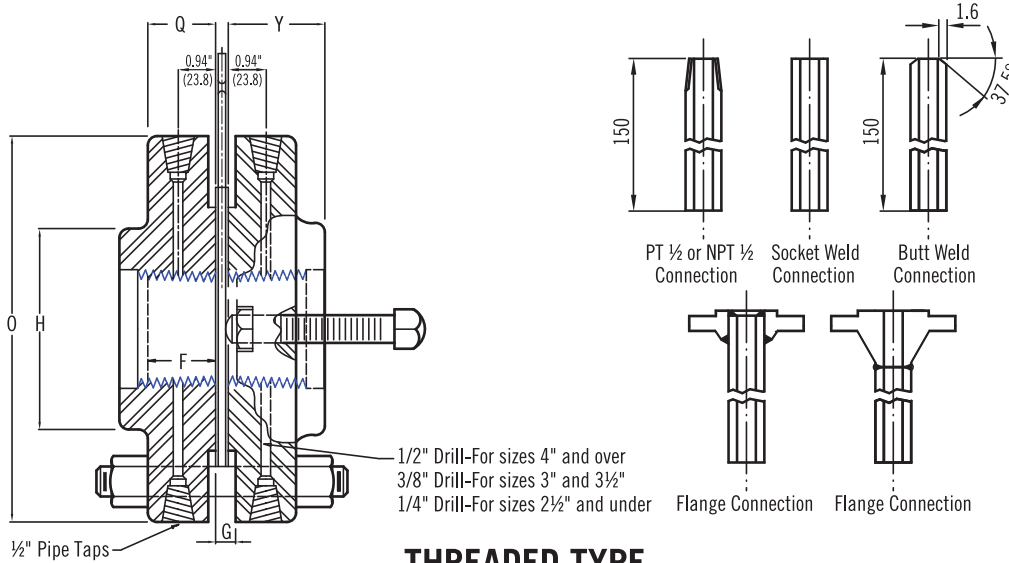

THREADED TYPE

unit:mm

300 LB.

NOMINAL PIPE SIZE	OUTSIDE DIAM OF FLANGE	THICKNESS OF FLANGES	DIAM. OF HUB	LENGTH THROUGH HUB	DIAM. OF TO RAISED FACE	DIAM. OF BORE	HEIGHT TO COUNTER BORE	FACE COUNTER BORE HEIGHT	DEPTH OF JACK SCREW SLOT	NUMBER OF BOLT HOLES	DIAM. OF BOLT HOLES	DIAM. OF BLOTS	LENGTH OF BOLTS	BOLT CIRCLE	APPROX. WEIGHT UNIT lb.
					THREADED										
	O	Q	H	Y		F	G								
1	123.8	38.1	54.0	47.6	71.4	34.5	38.1	20.6	9.5	4	17.5	15.9	101.6	88.9	6.8
1½	155.6	38.1	44.5	47.6	93.7	49.5	38.1	15.9	12.7	4	20.6	19.1	108.0	114.3	8.6
2	165.1	38.1	84.1	49.2	109.5	62.0	38.1	12.7	9.5	8	17.5	15.9	101.6	127.0	10.4
2½	190.5	38.1	100.0	50.8	128.6	76.7	44.5	15.9	12.7	8	20.6	19.1	108.0	149.2	14.1
3	210.0	38.1	117.5	52.4	147.6	90.7	44.5	12.7	12.7	8	20.6	19.1	108.0	168.3	17.7
4	254.0	38.1	146.1	54.0	179.4	116.1	44.5	11.1	12.7	8	20.6	19.1	108.0	200.0	27.2

Ordering Information

Individual Specification			Requirement		Requirement	
1	Tag No.	With S.S. Tag Nameplate				
2	Maker					
3	Model No.					
4	Quantity					
5	P&ID No.					
6	Line No. / Vessel No.					
7	Line Size	Sched No.				
8	Accuracy					
9	FCFC s Painting or Makers Painting STD					
Orifice Plates						
10	Plate Type					
11	Applied Code or Standard					
12	Plate Material					
13	Plate Thickness	(mm)				
14	Bore / Diameter Ratio	(d/D)				
15	Drain Hole	Vent Hole				
Flange & Ring						
16	Pipe Material					
17	Type (Flange or Ring)					
18	Flange / Ring Type					
19	Flange Conn. & Rating					
20	Flange / Ring Material					
21	Gasket Material					
22	Tap Type					
23	Tap Conn.					
24	Tap Material					
Accessories						
25	Bolts & Nuts	Jack Screws				
26	Drain Plugs	Material				
27	Tap Valve (½" x 2pc)	Material				
28	Others Material (Bolts & Nuts, ...)					
Operating Condition						
29	Fluid & State					
30	Flow Rate: Norm.	Max. (T/Hr)				
31	Press. Norm.	Max. (kg/cm ² G)				
32	Temp. Norm.	Max. (°C)				
33	Specific Gravity Density					
34	Molecular Weight					
35	Viscosity Range	(cp)				
36	Compression Factor					
37	Ratio of Spec. Heat	(Cp/Cv)				
38	Measuring Range					
39	Diff. Pressure Range					

* Please fill in above block on request.