

ONE PIECE BALL VALVE

NR-1

Technical Data

Full Port, 1 piece type

Material: Wetted parts ASTM A351 CF8M / 316

Connection Size: ¼”(8mm), ⅜”(10mm), ½”(15mm), ¾”(20mm), 1”(25mm), 1¼”(32mm), 1½”(40mm), 2”(50mm)

Connection Type: Thread

Locking Device: Valve operated locking in open or closed position

Working Temperature Limited: -20°F ~ 350°F (-5°C ~ 175°C)

Working Pressure Limited: 1000psi (70kg/cm²) for ¼”~1”; 800psi (56kg/cm²) for 1¼”~2”;

Valves inspected and tested according to **API 598 standard**.



Dimensions

General Type

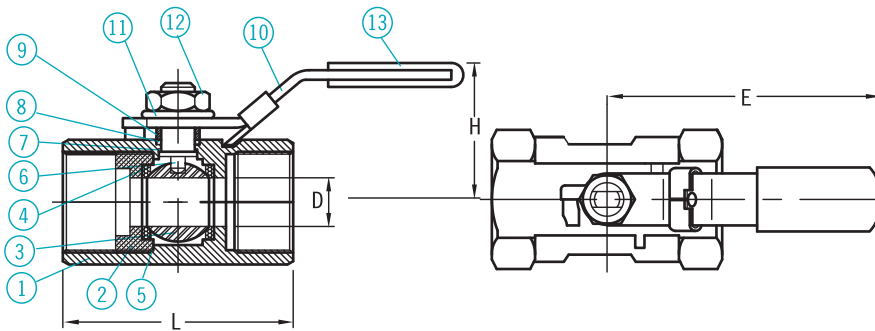

unit=mm

mm	Size inch	øD±0.5	L±2.0	H±3.0	E±3.0	CV Factor	TORQUE Inch/Lbs	Wt/Kg
08	¼	5	40	27	72	3.8	11	0.07
10	⅜	6.8	44	29	87	4	11	0.12
15	½	9.2	55	35	100	4.5	12	0.20
20	¾	12.5	59	45	100	9	18	0.29
25	1	15	70	53	117	16	34	0.43
32	1¼	20	78	55	117	24	44	0.71
40	1½	25	83	71	158	37	64	0.84
50	2	25	99	77	158	68	80	1.35

Butterfly Type

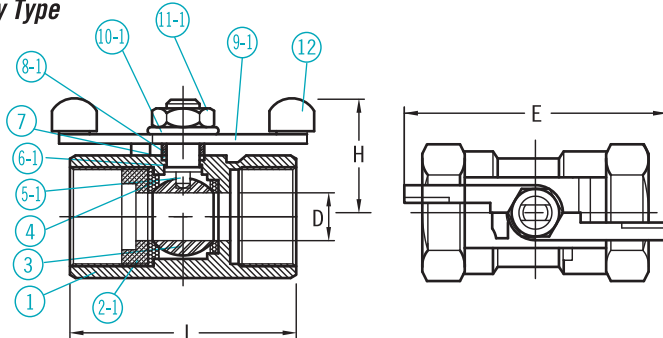

unit=mm

mm	Size inch	øD±0.5	L±2.0	H±3.0	E±3.0	CV Factor	TORQUE Inch/Lbs	Wt/Kg
08	¼	5	40	29	50	3.8	11	0.07
10	⅜	6.8	44	30	54	4	11	0.12
15	½	9.2	55	35	57	4.5	12	0.20
20	¾	12.5	58	40	57	9	18	0.29

Parts List

Item	Parts Name	Material
1	Body	ASTM A351 CF8M / 316
2	Insert	ASTM A351 CF8M / 316
2-1	Seat Retainer	ASTM A351 CF8M / 316
3	Ball	ASTM A351 CF8M / 316
4	Ball Seat	PTFE (RTFE)
5	Joint Gasket	PTFE
5-1	Stem	AISI 304
6	Stem	AISI 304
6-1	Stem Packing	PTFE
7	Thurst Washer	PTFE
8	Stem Packing	PTFE
8-1	Stem Washer	PTFE
9	Stem Washer	AISI 304
9-1	Handle	AISI 304
10	Handle	AISI 301
10-1	Spring Washer	AISI 304
11	Spring Washer	AISI 304
11-1	Stem Nut	AISI 304
12	Stem Nut	AISI 304
13	Plastic Cover	Plastic

Pressure-Temperature

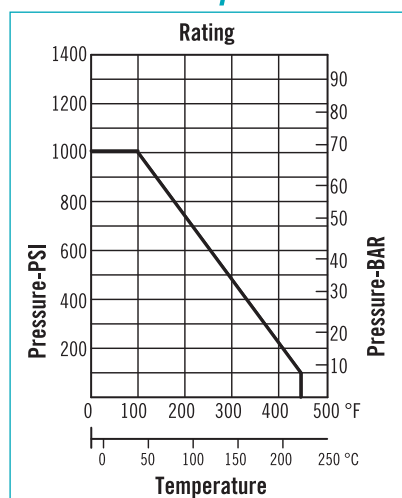

Ordering Information

NR-1	Code	Type
	G	General type
	B	Butterfly type
		Code Body Material
	S	CF8M / SS316
		Code Connection Size
	(A)	¼” (B) ⅜” (C) ½” (D) ¾”
	(E)	1” (F) 1¼” (G) 1½” (H) 2”
	(I)	2½” (J) 3” (K) 4”
NR-1		Complete Ordering Code