

TUBULAR TYPE LEVEL GAUGE

NL SERIES – With Protection Support Rod SL SERIES – With Protection Support Pipe

The tubular glass type is a simplest liquid level gauge for using in the pressure rating of 10 kg/cm² or under. The center to center length are over 1.5 meter. The intermediary joint ring would be used. Gauge glsas are made heat resistant borosilicate.

Technical Data

- Suitable Fluid:** Water, Oil, other chemical liquid
- Gauge Valve Material:** SS304, SS316, others available
- Gauge Tube Material:** Glass, P.V.C
- Seal Material:** Viton, Teflon available
- Gauge Valve Function:** With or Without ball check
- Max. Working Temperature:** 100°C
- Max. Working Pressure:** 4~7 kg/cm²
- Process Connection:** ½"~1½" Thread and Flange on request.
- Flange Rating:** JIS, ANSI, DIN available
- Drain Valve Connection:** standard ½"NPT(F); option available

Dimensions for NL Series

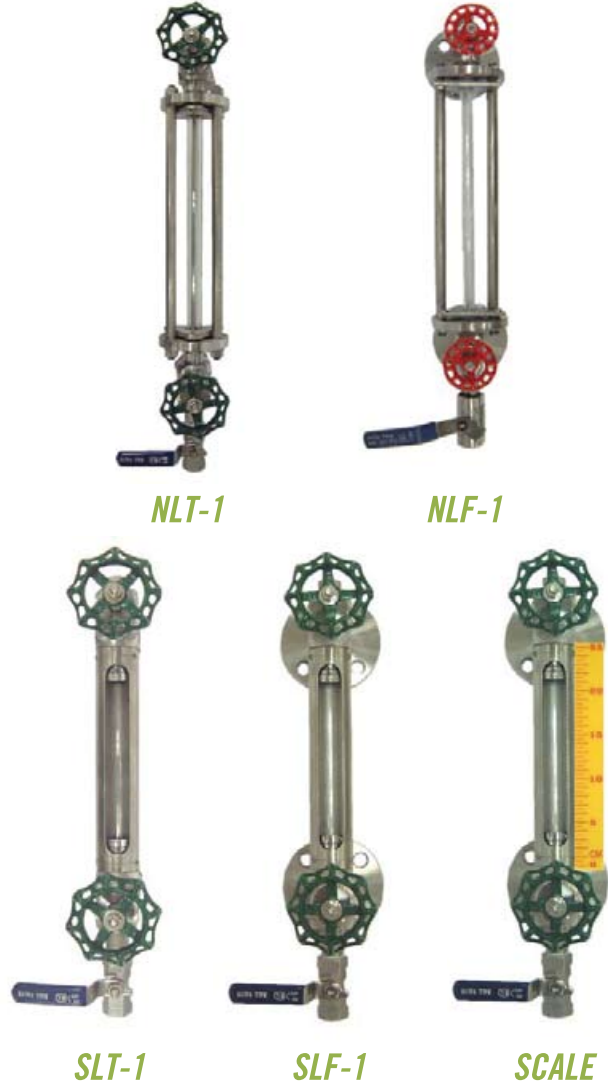
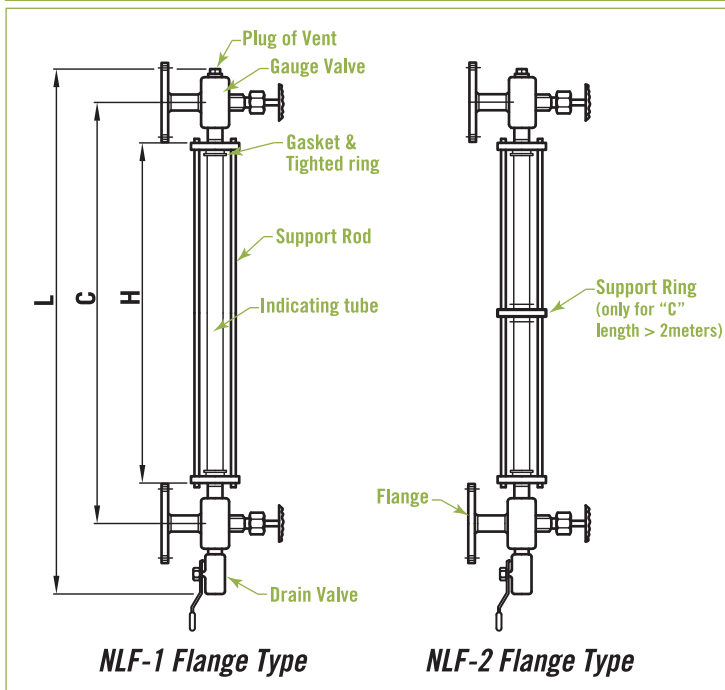
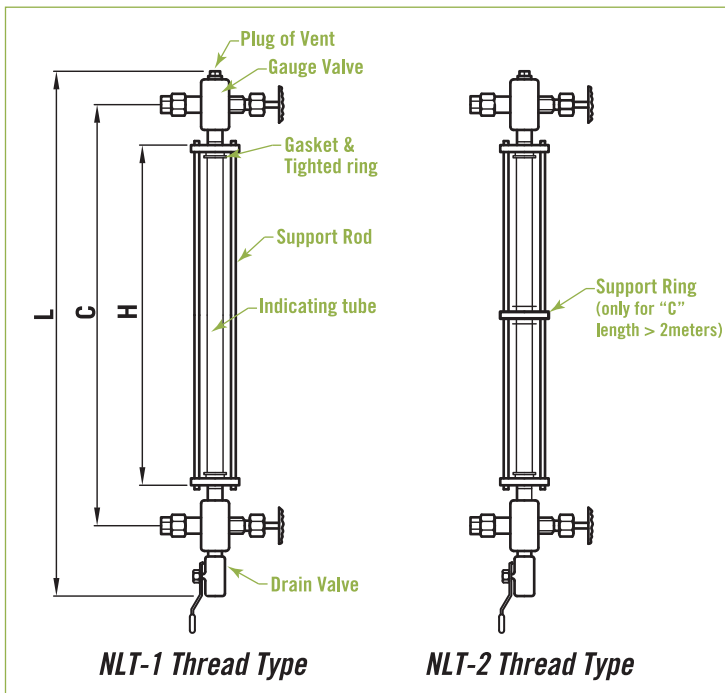

Item	mm	L	C	H	Section
1		400	300	200	1
2		600	500	400	1
3		800	700	900	1
4		1200	1100	1000	1
5		1300	1200	1100	1
6		1600	1500	1400	2
7		1900	1800	1700	2
8		2100	2000	1900	2

NOTE. The "C" dimension can be made by requirement of customer. Option available.

