

Introduction

The electromagnetic flowmeter uses Faraday’s Law of electromagnetic induction to measure the process flow. The device consists of two units: a detector, through which the fluid to be measured flows and in which low-level signals proportional to flow rates are obtained; and a converter, which supplies excitation current to the detector, and amplifies the signals from the detector and then processes and converts the signals into the 4–20mA dc current signal or communication signal. Combined with a multi-functional converter LF620 (combined type) or LF622 (separate type) equipped with its original patented noise-suppression circuit and advanced algorithms. The GF630 has a very high tolerance to noise, giving the unit a very stable output even for slurry fluid measurement. IR (Infrared) switches enable the parameter setting of the converter without removing the cover. Flow direction can be set in either way, and its unique 128 x 128 dot matrix LCD display allows the LCD to be rotated electronically to 90, 180 and 270 degrees without opening the cover. The terminal block in LCD side make easy to wire in case of the combined type.

The AF900 hand-held terminal (HART*¹ communicator) can be used to communicate with the flowmeter from a remote place. PROFIBUS-PA*² or Modbus*³ interface is available as an option.

*1: HART protocol (Highway Addressable Remote Transducer) is a communication protocol for industrial sensors recommended by the HCF (HART Communication Foundation).

*2: PROFIBUS is the communication protocol for factory and process automation that the PROFIBUS Organization recommends. Instead of analog control with a conventional analog signal (4-20mA), it is fieldbus which digitizes all signals. Flowmeters support PROFIBUS-PA.

*3: Modbus is the communication protocol that Modicon Inc. developed. Physical layer is RS485.

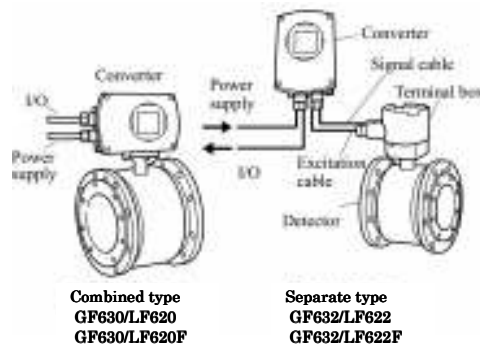

Figure 1. Configuration



GF630/LF620
GF630/LF620F

GF632

LF622
LF622F

Figure 2. GF630 Premium Value series Flowmeters



Certification number
 Z01207

Specifications

Overall Specifications

Measurement range in terms of flow velocity:
 0–0.3 m/s to 0–10 m/s (0–1.0 ft/s to 0–32.8 ft/s).
 0–0.1 m/s to 0–0.3 m/s (0–0.3 ft/s to 0–1.0 ft/s)
 range is available optionally for meter size 1/2” to 18” (15 to 450 mm).

Accuracy:

<15mm to 450mm>

Pulse output:

$V_s > 0.5 \text{ m/s (1.64 ft/s): } \pm 0.5 \% \text{ of rate.}$

$V_s < 0.5 \text{ m/s (1.64 ft/s): } \pm 0.3 \% \text{ of rate}$

$\pm 1 \text{ mm/s (0.039 inch/s).}$

Current output: plus $\pm 8 \mu\text{A}$ (0.05 % of span)

Note: Span = Range in the magmeters.

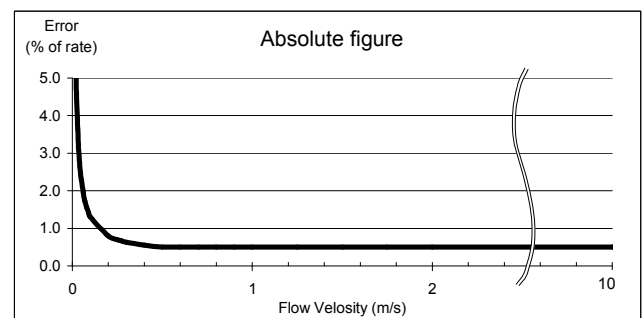

Accuracy

<500mm to 600mm>

Pulse output:

$V_s > 1.0 \text{ m/s (3.28 ft/s)}$: $\pm 0.5 \%$ of rate.
 $V_s < 1.0 \text{ m/s (3.28 ft/s)}$: $\pm 0.3 \%$ of rate
 $\pm 2 \text{ mm/s (0.079 inch/s)}$.

Current output: plus $\pm 8 \mu\text{A}$ (0.05 % of span)

Note: Span = Range in the magmeters.

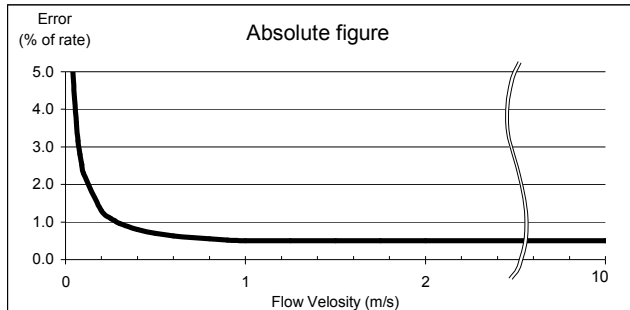

Accuracy

<700mm to 900mm>

Pulse output:

$V_s > 1.0 \text{ m/s (3.28 ft/s)}$: $\pm 0.8 \%$ of rate.
 $V_s < 1.0 \text{ m/s (3.28 ft/s)}$: $\pm 0.4 \%$ of rate
 $\pm 4 \text{ mm/s (0.157 inch/s)}$.

Current output: plus $\pm 8 \mu\text{A}$ (0.05 % of span)

Note: Span = Range in the magmeters.

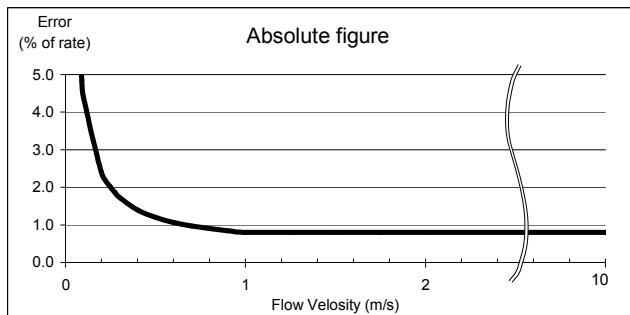

Accuracy

Note: The accuracy above is measured under standard operating conditions using the weighing method at Toshiba's flow calibration facility.

Fluid conductivity: 5 $\mu\text{S/cm}$ minimum

Fluid temperature:

- 20 to +100 °C: FEP lining (-4 to 212 °F)
- 20 to +120 °C: PTFE lining (-4 to 248 °F)
- 20 to +60 °C: Polyurethane lining (-4 to 140 °F)
- 10 to +60 °C: Chloroprene Rubber lining (14 to 140 °F)

Ambient temperature:

-20 to +60 °C (-4 to 140 °F)

Structure: IP 67 and MEMA 4X Watertight

Power consumption:

Standard: 10W(14VA)

at AC100V and Excitation current: 0.2A

MAX: 15W (22VA)

MAX: 17W(24VA) with PROFIBUS

Conformance to European Community Directives:

EMC directive 89/336/EEC
 The low voltage 93/68/EEC

Approved hazardous location certifications:

Model: GF630/LF620F and GF632/LF622F
 cFMus explosion proof:
 FM Class I, Division 2, Groups A,B,C, and D.
 FM Class II, Division 2, Groups E, F and G.
 FM Class III.

■ **Model GF630 and GF632 Detector**

Mounting style:

Flange connection type, ISO13359 for direct replacement of existing ISO13359 magmeters

Fluid pressure:

0 to 1 MPa (0 to 150 psi, or 0 to 10 bar)
 (To be within the applicable flange limitation)

Connection flange standards:

- ANSI 150 : 15 to 600 mm (1/2" to 24")
- AWWA : 700 to 900 mm (28" to 36")
- JIS10K : 15 to 900 mm (1/2" to 36")

Principal materials:

- Case** — carbon steel
- Flange material** — carbon steel
- Linings** —
 - FEP : Meter sizes 15 to 250mm (1/2" to 10")
 - PTFE : Meter sizes 300 to 600mm(12" to 24")
 - Polyurethane(PU) : Meter sizes 15 to 400mm (1/2" to 16")
 - Chloroprene Rubber (CR):
 Meter sizes 18" to 36" (450 to 900mm)
- Electrodes** —
 - Type - Super smooth, polished with self cleaning finish, and non stick shape
 - 316L stainless steel (for PU, CR lining)
 - Hastelloy C equivalent (for FEP, PTFE lining).
- Measuring tube material** — 304 stainless steel
- Terminal box** — Aluminum alloy (for separate type)

Grounding ring —

PU, CR, FEP lining: : None (std.)
316 stainless steel (opt.)
PTFE lining: : 316 stainless steel (std.)

Coating: Corrosion resistant resin coating (std.),
pearl-gray colored

Dimensions and weights: See Figure 3 and 4.

Cable connection port: for separate type detectors.

Applicable diameter — 11 to 13mm
(0.433 to 0.512 inch)

Cable glands —

GF632 without cFMus Approval :
Provided as standard, G1/2 male screws

GF632 with cFMus Approval :
Not provided
1/2-14NPT male screws are required.

■ Model LF620 and LF622 converters**Input signals**

Analog signal — the voltage signal from detector,
proportional to process flow rate (for LF622
separate type converter).

Digital input DI

Signal type: 20 to 30Vdc voltage signal
Input resistance: 2.7k Ω
Number of inputs: one point

Note: DI cannot be used with the Modbus
communication.

DI function — One of the following functions
can be assigned to the DI signal.

Range switching — Selects either the higher or
lower range in the unidirectional or
bidirectional 2-range setting.

Totalizer control — Starts and stops the built-in
totalizer.

Fixed-value outputs — Outputs fixed-values for
current and pulse outputs.

Zero adjustment — Executes zero adjustment
(on-stream at zero flow rate).

Output signals**Current output:**

4–20mA_{dc} (load resistance 0 to 750 Ω)

Note: The current output cannot be used with
the PROFIBUS-PA communication.

Digital outputs — Two points are available as
follows.

Digital output DO1 :

Output type: Transistor open collector
Number of outputs: One point
Output capacity: 30Vdc, 200mA maximum

Note: DO1 cannot be used if Modbus

communication connection is 3 lines.

Digital output DO2 :

Output type: Solid-state relay output (non
polarity)

Number of outputs: One point

Output capacity: 150Vdc, 150mA maximum
or 150Vac (peak to peak), 100mA maximum

Note: DO2 cannot be used with the Modbus
communication.

DO1 and DO2 functions — One of the following
functions can be assigned to DO1 and/or DO2.

- **Pulse output (available only for DO1,DO2)**

Pulse rate: Max 10kHz (10,000pps) (DO1)
Max 100Hz (100pps) (DO2)

(Over 1kpps, auto-setting)

Pulse width: 0.3 to 500ms (but less than half of
the period for 100% flow rate)

Note: The same and simultaneous pulse is not
available between DO1 and DO2.)

- **Multi-range selection outputs (Note 1)**

- **High, High high, Low, and/or Low low alarm
outputs (Note 2)**

- **Empty pipe alarm output (Note 2)**

- **Digital Output Active Status (DO1 and DO2)
(Note 2)**

- **Preset count output**

- **Converter failure alarm output**

Note 1: Two outputs (DO1 and DO2) are needed
for 4-range switching and forward/reverse
2-range switching.

Note 2: Normal Open (default set) or Normal
Close is selected for alarm outputs when
programming.
When power failure occurs, unit will be fault to
Normal Open.

Communications output :

- **HART (std.)**

Digital signal is superimposed on 4–20mA_{dc}
current signal as follows:

Conforms to HART protocol

Load resistance: 240 to 750 Ω

Load capacitance: 0.25 μ F maximum

Load inductance: 4mH maximum

- **PROFIBUS (opt.)**

Protocol : PROFIBUS-PA

Baud rate : 31.25kbps

Bus voltage : 9-30VDC

Consumption electric current of bus:less than 16mA

Manufacture Ident-No. : 093B_{HEX}

Standard Ident-No. : 9740_{HEX}

Slave address : 0-126 (Default address is 126)

Profile : Profile Ver.3.01 for Process Control
Devices

Function blocks : AI(Flow) \times 1 , Totalizer \times 1

•Modbus(opt.)

Physical layer : RS485

Protocol : Modbus

Mode : RTU

Baudrate : 4800, 9600, 19200bps

Data length : 8bit

Parity bit : None, Odd, Even

Stop bit : 1bit, 2bit

Error check : CRC-16

Max. station number : 32(with Master device)

Max. cable length : 1.2km (Note)

Note: This length is specification of 3 line connection.**LCD display:**Full dot-matrix 128×128 dot LCD display
(back-light provided)

The data on the LCD inside the converter can rotate to 90, 180, and 270 degrees by a software, without rotating the indicator itself. (Combined type only)

Parameter settings — Parameters can be set as follows:

- **IR Switches:** Three key switches are provided to set configuration parameters.
- **Digital communication:** The AF900 hand-held terminal or PROFIBUS, Modbus is needed to set parameters.
- **Zero adjustment:** Zero point adjustment can be started by pressing the switch in the converter.

Damping:

0.5 to 60 seconds (selectable in one second increments)

Zero and span calibration:

Built-in calibration signal source allows converter unit check.

Conditions when power fails:

Parameter setting values are stored in non-volatile memory and the values will be restored when the power returns to normal condition. The outputs and display will remain as follows when power fails.

- Current output: 0mA_{dc}
- Digital output: OFF
- LCD display: No display
- PROFIBUS: No communication

Power supply:

One of the following can be selected:

- 100 to 240Vac, 50/60Hz (std.)
(allowable voltage 80 to 264Vac)
- 24Vdc (allowable voltage 18 to 36Vdc)
- 110Vdc (allowable voltage 90 to 130Vdc)

Surge protection:

Arresters are installed in the power supply and a current signal output circuit to help protect the meter from lightning and improve personnel safety.

Case: Aluminum alloy (equal to IP 67)**Coating:** Acrylic resin-baked coating, pearl-gray colored**Cable connection port:****Cable glands** —

LF620 and LF622 without cFMus Approval:

Provided as standard, G 1/2 male screws.

OD of cable ϕ 11 to 13mm

Material Nylon 66

G 1/2 male screws.

Note: When PROFIBUS or Modbus option are specified, cable glands size is ϕ 6~8mm for signal cable, ϕ 11~13mm for power cable.

LF620F and LF622F with cFMus Approval:

Not provided, 1/2-14NPT male screws are required.

Applicable diameter —

11 to 13mm (0.433 to 0.512 inch)

Note: When PROFIBUS option is specified, cable gland size is ϕ 6~8mm for signal cable, ϕ 11~13mm for power cable.**Vibration resistance:**

No resonance to the following levels of vibration:

- 10 to 150Hz with acceleration of 9.8m/s²
- Vibration of 30Hz with 29.4 m/s² in 4h in each direction will not cause any defect to unit.

Note: Avoid using the flowmeter in an environment with constant vibration.**Converter LF622 Dimensions and Weights:**

See Figure 4 (for separate type)

MTBF:Converter: 220,000 hours (25 years) at 25 °C
(77 °F) based on strict military specification
MIL-HDBK-217FDetector: 350,000 hours (40 years) at 25 °C
(77 °F) based on strict military specification
MIL-HDBK-217F

Installation

■ Dimensions

Combined type GF630/LF620 and GF630/LF620F

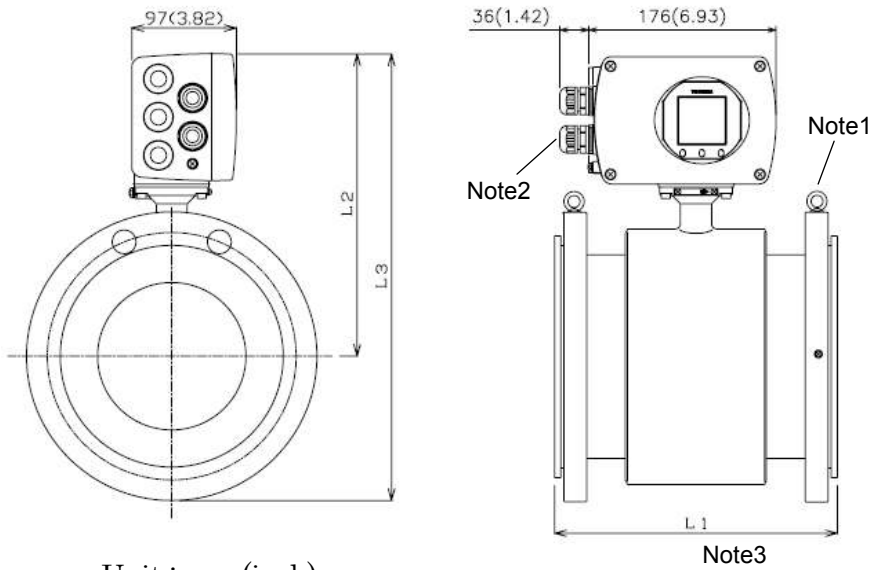

Unit : mm (inch)

- Note1:** Eye bolts are provided at the flange for flowmeters sized 200mm (8") or above.
- Note2:** Cable glands are not provided for GF630/LF620F cFMus approved type. Refer to the part Cable connection port at detector.
- Note3:** L1 of PTFE lining contains the thickness of grounding rings.
- Note4:** The weight of PTFE lining includes the weight of grounding rings.
- Note5:** 1 inch = 25.4mm

JIS 10K								
Size (mm)	L1 (mm)	L2 (mm)	L3 (mm)	No. of bolts	Weight (kg) approx.			
					FEP	PTFE	PU	CR
15	200	205	253	4	7		7	
25	200	215	278	4	8		8	
32	200	220	288	4	10		10	
40	200	225	295	4	11		11	
50	200	235	313	4	12		12	
65	200	248	335	4	15		15	
80	200	253	345	8	16		16	
100	250	264	369	8	23		23	
125	250	284	409	8	29		29	
150	300	299	439	8	34		34	
200	350	324	489	12	48		48	
250	450	344	544	12	70		70	
300	500	369	591	16		101	93	
350	550	391	636	16		137	127	
400	600	419	699	16		149	136	
450	600	441	751	20		171		159
500	600	466	804	20		185		171
600	600	521	919	24		253		234
700	700	562	1015	24				350
750	750	588	1073	24				400
800	800	618	1128	28				450
900	900	669	1229	28				500

ANSI 150 (AWWA for meter size 28" to 36")								
Size (inch)	L1 (inch)	L2 (inch)	L3 (inch)	No. of bolts	Weight (lbs) approx.			
					FEP	PTFE	PU	CR
1/2	7.9	8.1	10.0	4	16		16	
1	7.9	8.5	10.9	4	18		18	
1-1/4	7.9	8.7	11.3	4	20		20	
1-1/2	7.9	8.9	11.6	4	23		23	
2	7.9	9.3	12.3	4	29		29	
2-1/2	7.9	9.8	13.2	4	34		34	
3	7.9	10.0	13.6	4	42		42	
4	9.8	10.4	14.5	8	56		56	
5	9.8	11.2	16.1	8	71		71	
6	11.8	11.8	17.3	8	84		84	
8	13.8	12.8	19.3	8	128		128	
10	17.7	13.5	21.4	12	188		188	
12	19.7	14.5	23.3	12		292	274	
14	21.7	15.4	25.0	12		349	327	
16	23.6	16.5	27.5	16		430	402	
18	23.6	17.4	29.6	16		468		441
20	23.6	18.3	31.7	20		538		508
24	23.6	20.5	36.2	20		741		699
28	27.6	22.1	40.0	28				772
30	29.6	23.1	42.2	28				882
32	31.5	24.3	44.4	28				993
36	35.5	26.3	48.4	32				1103

Figure 3. GF630/LF620 and GF630/LF620F combined type flowmeters
Meter sizes 15mm (1/2") t 900mm (36")

Separate type GF632/LF622 and GF632/LF622F

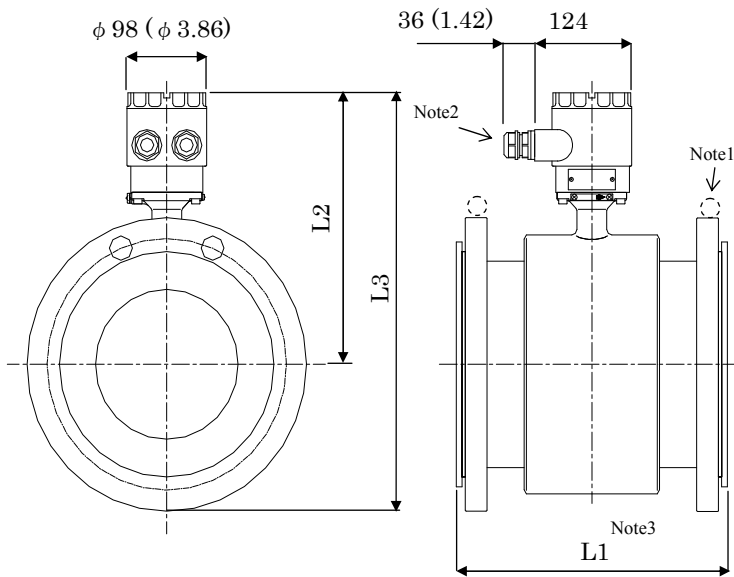

- Note1:** Eye bolts are provided at the flange for flowmeters sized 200mm (8") or above.
- Note2:** Cable glands are not provided for GF632/LF622F cFMus approved type. Refer to the part Cable connection port at detector.
- Note3:** L1 of PTFE lining contains the thickness of grounding rings.
- Note4:** The weight of PTFE lining includes the weight of grounding rings.
- Note5:** 1 inch = 25.4mm

Unit : mm (inch)

Size (mm)	L1 (mm)	L2 (mm)	L3 (mm)	No. of bolts	Weight (lbs) approx.			
					JIS 10K			
					FEP	PTFE	PU	CR
15	200	172	220	4	5		5	
25	200	182	245	4	6		6	
32	200	187	255	4	8		8	
40	200	192	262	4	9		9	
50	200	202	280	4	10		10	
65	200	215	302	4	13		13	
80	200	220	312	8	14		14	
100	250	231	336	8	21		21	
125	250	251	376	8	27		27	
150	300	266	406	8	32		32	
200	350	291	456	12	46		46	
250	450	311	511	12	68		68	
300	500	336	558	16		99	91	
350	550	358	603	16		135	125	
400	600	386	666	16		147	134	
450	600	408	718	20		169		157
500	600	433	771	20		183		169
600	600	488	886	24		251		232
700	700	529	982	24				348
750	750	555	1040	24				398
800	800	585	1095	28				448
900	900	636	1196	28				548

Size (inch)	L1 (inch)	L2 (inch)	L3 (inch)	No. of bolts	Weight (kg) approx.			
					ANSI 150 (AWWA for meter size 28" to 36")			
					FEP	PTFE	PU	CR
1/2	7.9	4.9	8.5	4	12		12	
1	7.9	5.1	9.3	4	14		14	
1-1/4	7.9	5.3	9.7	4	16		16	
1-1/2	7.9	5.4	10.1	4	18		18	
2	7.9	5.7	10.9	4	25		25	
2-1/2	7.9	6.1	11.9	4	29		29	
3	7.9	6.2	12.4	4	38		38	
4	9.8	6.5	13.6	8	51		51	
5	9.8	7.1	14.9	8	67		67	
6	11.8	7.5	15.9	8	80		80	
8	13.8	8.2	18.2	8	124		124	
10	17.7	8.8	20.2	12	183		183	
12	19.7	9.5	22.7	12		287	269	
14	21.7	10.1	24.6	12		344	322	
16	23.6	10.9	26.9	16		426	397	
18	23.6	11.5	28.6	16		463		437
20	23.6	12.2	30.8	20		534		503
24	23.6	13.8	35.2	20		737		695
28	27.6	20.8	39.1	28				768
30	29.6	21.9	41.3	28				878
32	31.5	23.0	43.9	28				988
36	35.5	25.1	48.1	32				1209

Figure 4. Separate type detectors GF632 Meter sizes 15mm (1/2") to 900mm (36")

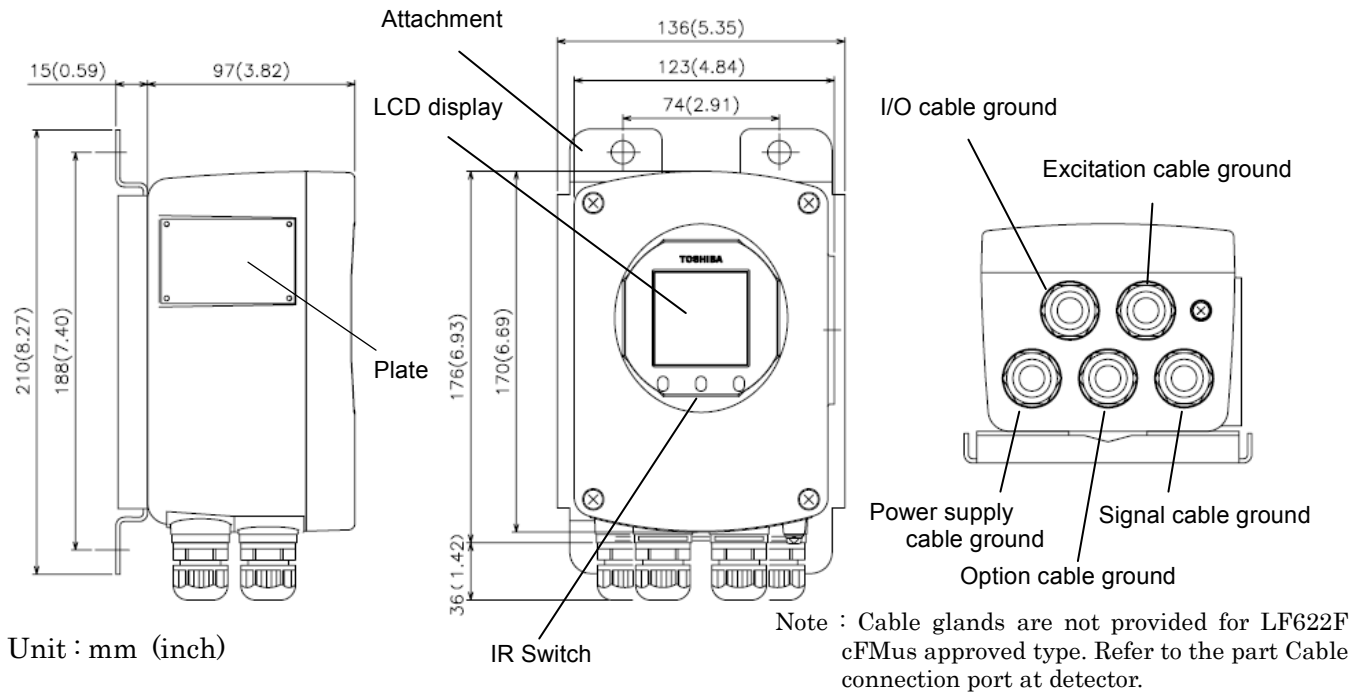

Figure 5. Separate type converter LF622 and LF622F

External Connections

- Combined type GF630//LF620 and GF630/LF620F flowmeter

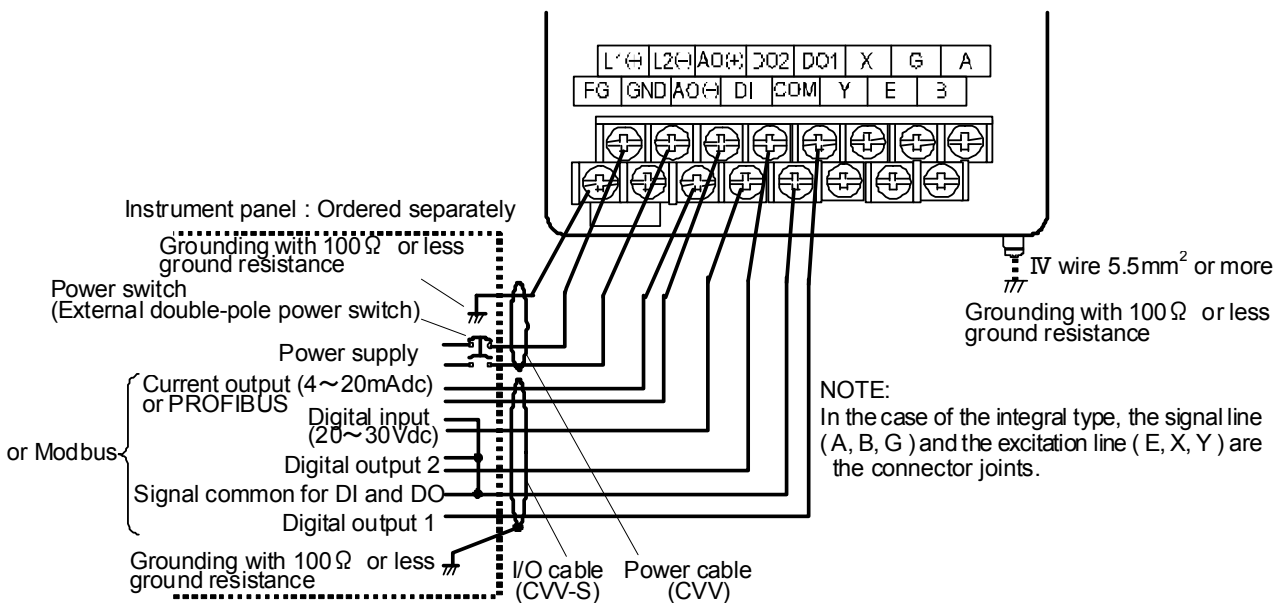

Figure 6. Combined type GF630/LF620 and GF630/LF620F flowmeters Wiring Diagram

• Separate type GF632/LF622 and GF632/LF622F flowmeter

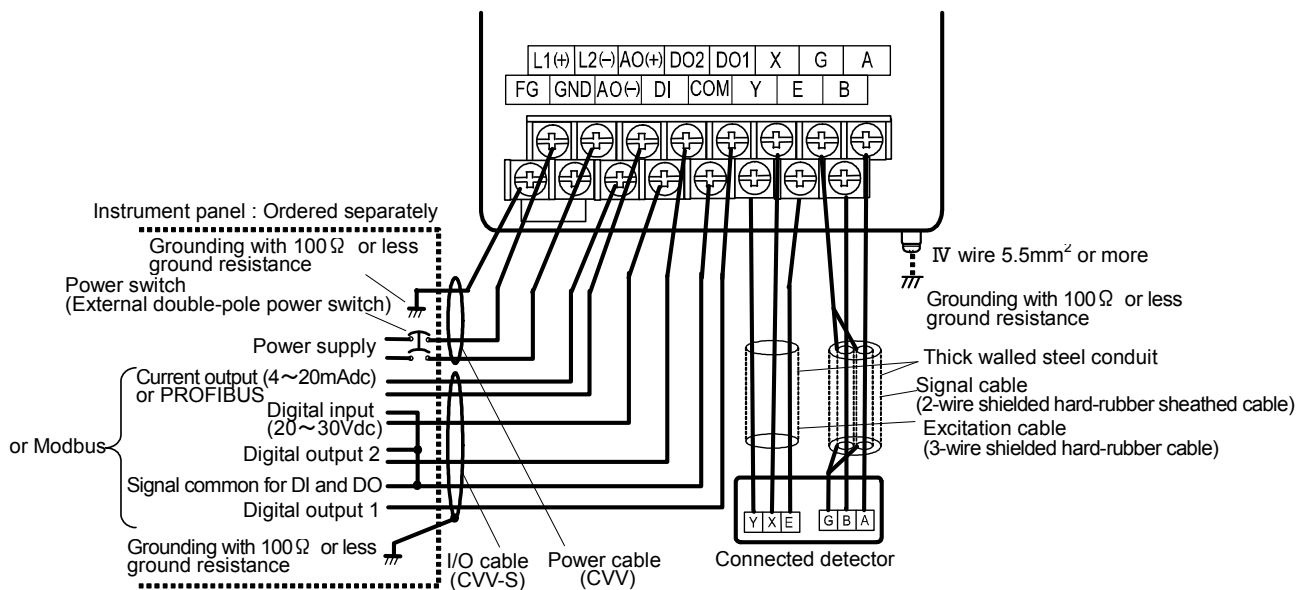

Figure 7. Separate GF632/LF622 and GF632/LF622F type Converter Wiring Diagram

- *1 Locate an external double-pole power switch on the power line near the flowmeter within easy reach of operation. Use the appropriate switch rating as shown below:
 Switch rating: 250Vac, 6A or more In rush current: 15A or more

Table 1. LF620, LF620F, LF622 and LF622F Converters Signal Table

Symbol	Description	Cable
L1 (+)	Power supply	Power cable (CVV)
L2 (-)		
GND	Ground (for arrester)	
FG	Frame ground	
DI	Digital Input (20~30Vdc)	I/O cable (CVV-S)
DO1	Digital Output 1	
DO2	Digital Output 2	
COM	Signal Common for DI, DO1, DO2	
+	Current Output (4~20mAdc) or PROFIBUS	Shielded cable for PROFIBUS-PA
-		
X	Excitation Output	Excitation cable (for LF622, LF622F only)
Y		
E		
A	Signal Input	Signal cable (for LF622, LF622F only)
B		
G		

Note: Symbol of the terminal is changed as follows for Modbus.

DO2 → T+, DI → T-, COM → TG

Symbol	Description	Cable
T+	Modbus(+)	Twist-pair polyethylene insulated vinyl sheath cable (JKEV,AWG24(0.2mm ²))
T-	Modbus(-)	
TG	Modbus(GND)	

■ Wiring Precautions

- (1) Explosion proof type flowmeters are not provided cable glands. Refer to the part Cable connection port at detector and converter.
- (2) Connect the grounding wire (IV wire 5.5mm² or more) to a good earth ground (100Ω or less ground resistance). Make the wire as short as possible. Do not use a common ground shared with other equipment where earth current may flow. An independent earth ground is recommended.
- (3) The allowable cable lengths between the detector and converter for the separate type flowmeter depend on the electrical conductivity of the object fluid. See Figure 8.
- (4) DO1, DO2, and DI use the same common terminal (COM). This COM can not connect to other equipments which have their own ground terminal. (Power supply for connecting to DI or DO, etc...) Need to wire separately.

■ Wiring Precautions (PROFIBUS or Modbus)

- (1) For wiring path, avoid places near electrical equipment that may cause electromagnetic induction or electrostatic induction interference (such as a motor, transformer and wireless transmitter).
- (2) Use a PROFIBUS-PA cable or a RS485 twist-pair cable for signal cable. In addition, make sure to use a shielded cable to improve noise resistance. Furthermore, installation of signal cable in metal conduit is recommended.
- (3) General cables are designed for indoor use where cables are not exposed to humidity, rain, etc. When you install cables, make sure to check the operating conditions such as the operating temperature range of the cable by contacting its manufacturer.
- (4) When you carry out cable end treatment of cable, use a dedicated cable stripper etc. so that the core wire of the cable will not be nicked or damaged. In addition, for cables, be careful of allowable maximum bend diameter etc. (Basically, do not install cables in a way cables are twisted or bent.)
- (5) Consider installing a PROFIBUS-PA arrester in the communication path of PROFIBUS-PA so that the electromagnetic flowmeter will not be affected by lightning etc.
- (6) The electromagnetic flowmeter is not equipped with terminating resistors. Use the terminating resistor unit for PROFIBUS-PA or junction box, if necessary.
- (7) Only one PROFIBUS-PA cable goes through a

cable gland of the Electromagnetic Flowmeter. Use the junction box at system configuration.

- (8) Install a terminator to flowmeter that connected to end of Modbus network.

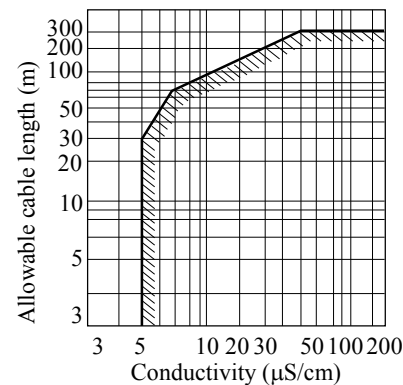

Figure 8. Electrical Conductivity and Cable Length

■ Meter Size

To select the meter size:

See Table 2 to 3 and find meter sizes within the velocity of 0.1 to 10m/s for a specified full-scale (measuring range high limit) flow. Select one that has its full-scale velocity between 1 and 3m/s.

Note: Make sure the full-scale flow rate used for the final planning stage stays within 10m/s in terms of flow velocity.

Table 2. Flow Rate and Flow velocity (SI unit)

Unit: m³/h

Size (mm)	Flow rate				
	0.1 m/s	0.3 m/s	1.0 m/s	3 m/s	10 m/s
15	0.0636	0.1908	0.6361	1.908	6.361
25	0.1767	0.5301	1.767	5.301	17.67
32	0.2895	0.8686	2.895	8.686	28.95
40	0.4523	1.357	4.523	13.57	45.23
50	0.7067	2.120	7.067	21.20	70.67
65	1.195	3.583	11.95	35.83	119.5
80	1.809	5.428	18.09	54.28	180.9
100	2.827	8.482	28.27	84.82	282.7
125	4.417	13.25	44.17	132.5	441.7
150	6.361	19.08	63.61	190.8	636.1
200	11.31	33.93	113.1	229.3	1,131
250	17.67	53.01	176.7	530.1	1,767
300	25.45	76.34	254.5	763.4	2,545
350	34.64	103.9	346.4	1,039	3,464
400	45.23	135.7	452.3	1,357	4,523
450	57.25	171.7	572.5	1,717	5,725
500	—	212.1	706.9	2,121	7,069
600	—	305.4	1,018	3,054	10,180
700	—	415.6	1,385	4,156	13,850
750	—	477.1	1,590	4,771	15,900
800	—	542.9	1,810	5,429	18,100
900	—	687.1	2,290	6,871	22,900

Table 3. Flow Rate and Flow velocity (U.S. unit)

Unit: gal/min

Size (inch)	Flow rate				
	0.3ft/s	0.98ft/s	3ft/s	10ft/s	32.8ft/s
1/2'	0.2801	0.8403	2.561	8.532	28.01
1	0.7781	2.334	7.115	23.72	77.81
1 ¼	1.275	3.824	11.66	38.86	127.5
1 ½	1.992	5.975	18.21	60.71	199.2
2	3.112	9.337	28.46	94.86	311.2
2 ½	5.260	15.78	48.09	160.3	526.0
3	7.967	23.90	72.85	242.8	796.7
4	12.45	37.35	113.8	379.4	1,245
5	19.45	58.35	177.9	592.9	1,945
6	28.01	84.03	256.1	853.8	2,801
8	49.80	149.4	455.3	1,518	4,980
10	77.81	233.4	711.5	2,372	7,781
12	112.0	336.1	1,025	3,415	11,200
14	152.5	457.5	1,394	4,648	15,250
16	199.2	597.5	1,821	6,071	19,920
18	252.1	756.3	2,305	7,684	25,210
20	—	933.7	2,846	9,486	31,120
24	—	1,344	4,098	13,660	44,820
28	—	1,830	5,578	18,590	61,000
30	—	2,101	6,403	21,340	70,020
32	—	2,390	7,285	24,280	79,670
36	—	3,025	9,221	30,740	100,800

■ Calibration Range

If the calibration range is not specified, the standard range as shown below will be used. If the range is specified, we will use the specified range for calibration.

Table 4. Standard Flow Range

Meter size mm (inch)	Standard flow range			
	Flow rate (m ³ /h)	Flow velocity (m/s)	Flow rate (gal/min)	Flow velocity (ft/s)
15 (1/2)	2	3.144	25	29.283
25 (1)	6	3.395	75	31.625
32 (1 1/4)	10	3.454	125	32.171
40 (1 1/2)	15	3.316	175	28.826
50 (2)	25	3.537	300	31.625
65 (2 1/2)	40	3.348	475	29.629
80 (3)	60	3.316	650	26.766
100 (4)	100	3.537	1,000	26.354
125 (5)	150	3.395	1,750	31.625
150 (6)	200	3.144	2,500	29.283
200 (8)	300	2.653	4,500	29.649
250 (10)	600	3.395	7,000	29.517
300 (12)	900	3.537	10,000	28.283
350 (14)	1,200	3.465	12,000	25.817
400 (16)	1,600	3.537	16,000	26.354
450 (18)	2,500	4.366	20,000	26.029
500 (20)	3,000	4.244	25,000	26.354
600 (24)	4,000	3.930	40,000	29.283
700 (28)	5,000	3.609	50,000	26.892
750 (30)	6,000	3.773	60,000	28.112
800 (32)	7,000	3.868	70,000	28.825
900 (36)	8,000	3.930	80,000	26.029

Note: The unit of "gal/min" is not exchanged (converted) by "m³/h".

■ Piping Precautions

- (1) Design piping so that the flowmeter detector pipe is always filled with the fluid being measured, whether the fluid is flowing or not.
- (2) The detector has no adjustable piping mechanism. Install an adjustable short pipe where needed.
- (3) The required straight pipe length should comply with the requirements as follows.
- (4) Be sure to ground the flowmeter according to the flow meter instruction manual.

Required straight pipe length

Upstream side	When using 90-degree bend, tee, diffuser or fully opened valve	$L \geq 5D$
	When using other types of valves	$L \geq 10D$
Downstream side	When no valve plate protrudes into the detector pipe	$L \geq 0$

L: Required straight pipe length, D: Meter size

**■ Piping materials (to be ordered separately)
Mating flanges:**

The flowmeter must be mounted with its detector pipe connected between the flanges in the pipeline. If no flanges are used where the flowmeter is to be mounted, mating flanges are needed.

Adjustable short pipe:

When both the upstream and downstream pipe sections cannot be adjusted laterally along the pipeline, an adjustable short pipe may be needed.

Reducers:

When the flowmeter with its Meter size smaller than that of the pipeline should be installed, reducers are needed on both ends of the flowmeter detector.

Reducers with pipe extensions:

Reducers with adjustable piping mechanism.

Gasket :

Gasket is needed for piping. In the case of the detector with grounding ring and Teflon lining, additional gasket is needed between grounding ring and lining face.

■ About establishment environment

Do not store or install the flowmeter :

- Where there is direct sunlight.
- Where excessive vibration or mechanical shock occurs.
- Where high temperature or high humidity conditions exist.
- Where corrosive atmospheres exist.
- Places that can be submerged under water.
- Where there is a sloped floor. To put the flowmeter temporarily on the floor, place it carefully with something, such as a block, to support it so that the flowmeter will not topple over.

In areas like the following, there may be the case that infrared switches do not function correctly. (If these are unavoidable, use an appropriate cover.)

- (1) Where unit (operation panel) is exposed to direct sunlight, reflection of light onto window pane and diffused light reflection.
- (2) Where smoke and steam may occur.
- (3) Where exposed to direct snow, ice or mud.

Ordering Information

1. When ordering the GF630 series flowmeters, refer to Tables 6 to 8 (Type Specification Codes). An entry must be made for each of the columns in each of these tables.
2. Fluid characteristics:
 - (1) Type of fluid to be measured and its characteristics
 - (2) Fluid temperature
 - (3) Fluid pressure
 - (4) Electrical conductivity of the fluid
3. Measuring range
4. I/O function setting
5. Ordering scope:
Flow calibration data: (required or not)
6. Other items
Specifications other than standard items

Consult a Toshiba representative before ordering when choosing materials of the wetted parts such as lining, electrodes, and grounding rings.

■ Ordering Grounding rings

When you purchase the grounding ring, refer to Table 5.

Table 5. Arrangement code of the Grounding ring

Meter size		JIS10K	ANSI150
mm	inch		
15	1/2"	5P8A1544P001	
25	1"	5P8A1544P002	
32	1-1/4"	5P8A1544P003	
40	1-1/2"	5P8A1544P004	
50	2"	5P8A1544P005	
65	2-1/2"	5P8A1544P006	5P8A1544P106
80	3"	5P8A1544P007	5P8A1544P107
100	4"	5P8A1544P008	
125	5"	5P8A1544P009	
150	6"	5P8A1544P010	
200	8"	5P8A1544P011	5P8A1544P111
250	10"	5P8A1544P012	5P8A1544P112
300	12"	5P8A1544P013	5P8A1544P113
350	14"	5P8A1544P014	5P8A1544P114
400	16"	5P8A1544P015	5P8A1544P115
450	18"	5P8A1544P016	5P8A1544P116
500	20"	5P8A1544P017	5P8A1544P117
600	24"	5P8A1544P019	5P8A1544P119
700	28"	5P8A1544P021	5P8A1544P121
750	30"	5P8A1544P022	5P8A1544P122
800	32"	5P8A1544P023	5P8A1544P123
900	36"	5P8A1544P025	5P8A1544P125

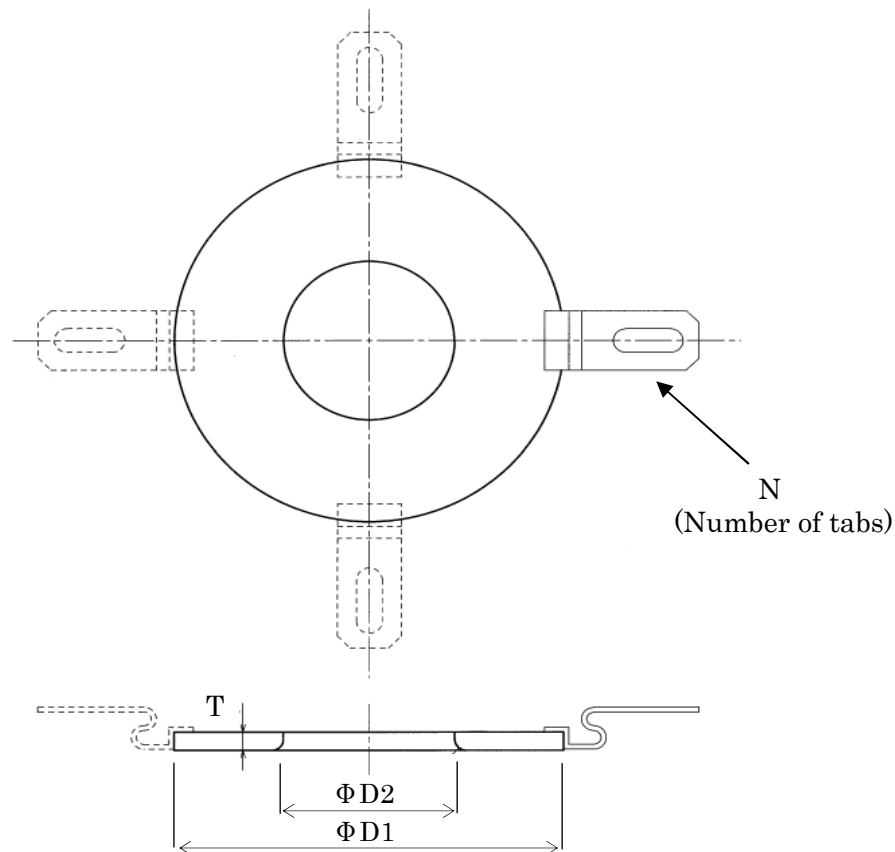

Meter size		JIS 10K (Unit: mm)				ANSI 150 (AWWA for 28" to 36") (Unit: inch)			
mm	inch	ΦD1	ΦD2	T	N	ΦD1	ΦD2	T	N
15	1/2	42	16	3.0	2	1.65	0.63	0.16	2
25	1	60	27	3.0	2	2.36	1.06	0.16	2
32	1-1/4	70	34	3.0	2	2.76	1.34	0.16	2
40	1-1/2	77	42	3.0	2	3.03	1.65	0.12	2
50	2	95	52	3.0	2	3.74	2.05	0.12	2
65	2-1/2	115	67	3.0	2	4.69	2.44	0.12	2
80	3	125	82	3.0	2	5.08	3.03	0.12	2
100	4	150	104	3.0	2	5.91	4.09	0.12	2
125	5	185	129	3.0	2	7.28	5.08	0.12	2
150	6	215	154	3.0	2	8.46	6.06	0.12	2
200	8	265	204	3.0	4	10.43	8.03	0.12	4
250	10	325	255	3.0	4	13.11	10.04	0.12	4
300	12	372	305	3.0	4	15.59	12.01	0.12	4
350	14	416	333	3.0	4	17.32	13.11	0.12	4
400	16	479	384	3.0	4	19.80	15.12	0.12	4
450	18	534	433	3.0	4	21.34	17.05	0.12	4
500	20	589	483	3.0	4	23.58	19.02	0.12	4
600	24	691	584	3.0	4	27.95	22.99	0.12	4
700	28	804	689	3.0	4	31.65	27.13	0.12	4
750	30	860	740	3.0	4	33.86	29.13	0.12	4
800	32	911	791	3.0	4	35.87	31.14	0.12	4
900	36	1011	892	3.0	4	39.80	35.12	0.12	4

Figure 9 Grounding ring
Meter sizes 15mm (1/2") to 900mm (36")

Table 6. Specification Code (Flange type detector GF630 (Combined type))

Model					Specification Code									Description	Lining				
1	2	3	4	5	6	7	8	9	10	11	12	13	14		PU	CR	FEP	PTFE	
G	F	6	3	0											Combined (Integral) type	●	●	●	●
															Meter size				
					0	1									15 mm (½")	●	-	●	-
					0	2									25 mm (1")	●	-	●	-
					0	3									32 mm (1-¼")	●	-	●	-
					0	4									40 mm (1-½")	●	-	●	-
					0	5									50 mm (2")	●	-	●	-
					0	6									65 mm (2-½")	●	-	●	-
					0	8									80 mm (3")	●	-	●	-
					1	0									100 mm (4")	●	-	●	-
					1	2									125 mm (5")	●	-	●	-
					1	5									150 mm (6")	●	-	●	-
					2	0									200 mm (8")	●	-	●	-
					2	5									250 mm (10")	●	-	●	-
					3	0									300 mm (12")	●	-	-	●
					3	5									350 mm (14")	●	-	-	●
					4	0									400 mm (16")	●	-	-	●
					4	5									450 mm (18")	-	●	-	●
					5	0									500 mm (20")	-	●	-	●
					6	0									600 mm (24")	-	●	-	●
					7	0									700 mm (28")	-	●	-	-
					7	5									750 mm (30")	-	●	-	-
					8	0									800 mm (32")	-	●	-	-
					9	0									900 mm (36")	-	●	-	-
							A								Connection flange standard				
							J								ANSI 150 (AWWA for meter size :700 to 900 mm)	●	●	●	●
															JIS 10K	●	●	●	●
															Lining				
							U								Polyurethane	●	-	-	-
							C								Chloroprene Rubber	-	●	-	-
							F								FEP	-	-	●	-
							P								PTFE (Note1)	-	-	-	●
															Electrode Material				
							B								316L stainless steel	●	●	-	-
							F								Hastelloy C (Equivalent)	-	-	●	●
															Flow and calibration velocity range				
							A								0.3 to 10 m/s (standard range calibration)	●	●	●	●
							B								0.3 to 10 m/s (specified range calibration)	○	○	○	○
							C								0.1 to 10 m/s (specified range calibration)	○	○	○	○
								1							Standard	●	●	●	●

Code explanation: ●: Standard ○: Option —: Not available

Note: The grounding rings are provided to PTFE Lining, which material is 316 stainless steel and gasket material is EPDM rubber.

Table 7. Specification Code (Flange type detector GF632 (Separate type))

Model					Specification Code										Description	Lining			
1	2	3	4	5	6	7	8	9	10	11	12	13	14	PU		CR	FEP	PTFE	
G	F	6	3	2											Separate (Remote) type	●	●	●	●
															Meter size				
					0	1									15mm (½")	●	-	●	-
					0	2									25mm (1")	●	-	●	-
					0	3									32mm (1¼")	●	-	●	-
					0	4									40mm (1½")	●	-	●	-
					0	5									50mm (2")	●	-	●	-
					0	6									65mm (2½")	●	-	●	-
					0	8									80mm (3")	●	-	●	-
					1	0									100mm (4")	●	-	●	-
					1	2									125mm (5")	●	-	●	-
					1	5									150mm (6")	●	-	●	-
					2	0									200mm (8")	●	-	●	-
					2	5									250mm (10")	●	-	●	-
					3	0									300mm (12")	●	-	-	●
					3	5									350mm (14")	●	-	-	●
					4	0									400mm (16")	●	-	-	●
					4	5									450mm (18")	-	●	-	●
					5	0									500mm (20")	-	●	-	●
					6	0									600mm (24")	-	●	-	●
					7	0									700mm (28")	-	●	-	-
					7	5									750mm (30")	-	●	-	-
					8	0									800mm (32")	-	●	-	-
					9	0									900mm (36")	-	●	-	-
					A										Connection flange standard	●	●	●	●
					J										ANSI 150 (AWWA for meter size :700 to 900 mm) JIS 10K	●	●	●	●
					U										Lining	●	-	-	-
					C										Polyurethane	-	●	-	-
					F										Chloroprene Rubber	-	-	●	-
					P										FEP PTFE (Note1)	-	-	-	●
					B										Electrode Material	●	●	-	-
					F										316L stainless steel Hastelloy C (Equivalent)	-	-	●	●
					A										Flow and calibration velocity range	●	●	●	●
					B										0.3 to 10 m/s (standard range calibration)	○	○	○	○
					C										0.3 to 10 m/s (specified range calibration) 0.1 to 10 m/s (specified range calibration)	○	○	○	○
					H										0.3 to 10 m/s (standard range calibration)	●	●	●	●
					J										0.3 to 10 m/s (specified range calibration)	○	○	○	○
					K										0.1 to 10 m/s (specified range calibration)	○	○	○	○
					1										Standard	●	●	●	●

Code explanation: ●: Standard ○: Option —: Not available

Note: The grounding rings are provided to PTFE Lining, which material is 316 stainless steel and gasket material is EPDM rubber.

Table 8. Specification Code for LF620/LF622 converters

Model				Specification Code										Contents	LF620 type	LF622 type	
1	2	3	4	5	6	7	8	9	10	11	12	13	14				
L	F	6	2												Electromagnetic flowmeter converter		
				0											Combined (Integral) type	●	—
				2											Separate (Remote) type	—	●
					A										Purpose		
					F										Standard	●	●
															cFMus class I, Division 2 approved	○	○
						A									Shape		
															Standard type with case	●	●
							A								Converter mounting fitting		
							C								None	●	○
							E								Panel, Accessory for wall mounting (BNP material: SUS304)	—	●
															Accessory for pipe installation (BNP material: SUS304)	—	○
								2							Digital input/output		
															Digital output points 2 (DO1+DO2) +Digital input point 1 (DI)	●	●
									1						Current output and Communication function		
									2						Current output + HART communication	●	●
									3						PROFIBUS communication (Current output is not usable)	○	○
															Current output + Modbus (RS485) communication	○	○
															(Digital outputs 2 (DO1+DO2) and Digital 1 (DI) input are not usable)		
									1						Power supply		
									2						100Vac-240Vac, 50/60Hz	●	●
									3						24Vdc	○	○
															110Vdc	○	○
										F					Instruction manual		
															English	●	●

Code explanation: ●: Standard ○: Option —: Not available

Note 1: When digital output 1 function and Modbus communication function are used at one time, TG (signal ground) of the Modbus communication function cannot be connected (2 line connection).

Table 9. Specification Code (Exciting Cable and Signal Cable for Separate type only)

Model			Specification Code					Description
1	2	3	4	5	6	7	8	
A	C	C						Dedicated preformed cable
	A							Nominal cross-sectional area of Exciting cable (Note 1) 1.25 mm ²
	B							2 mm ²
	A							Nominal cross-sectional area of Signal cable (Note 2) 0.75 mm ²
								Cable length
			0	0	1			1 m
			0	0	2			2 m
			0	0	3			3 m
			0	0	4			4 m
			0	0	5			5 m
			0	0	6			6 m
			0	0	7			7 m
			0	0	8			8 m
			0	0	9			9 m
			0	1	0			10 m
			0	1	5			15 m
			0	2	0			20 m
			0	2	5			25 m
			0	3	0			30 m
			0	3	5			35 m
			0	4	0			40 m
			0	4	5			45 m
			0	5	0			50 m
			0	6	0			60 m
			3	0	0			300 m

From 1 to 10 meters (3.3 to 32.8 feet), cable can be ordered in 1 meter increments.

From 10 to 50 meters (32.8 to 164 feet), cable can be ordered in 5 meters increments

From 50 to 300 meters (164 to 984 feet), cable can be ordered in 10 meters increments.

Notes:

- Exciting cable is a 3-wire chloroprene sheathed cable. For a nominal cross-sectional area of 1.25 mm², the overall diameter will be 12 mm (15/32 inch); for 2 mm², 13 mm(1/2 inch).
- Signal cable is a 2-wire shielded chloroprene sheathed cable with a nominal cross-sectional area of 0.75 mm² and an overall diameter of 12 mm (15/32 inch).
- Relation between exciting cable length and its nominal cross-sectional area and overall diameter is as follows.

Exciting cable length	Nominal cross-sectional area	Overall diameter
1 to 200 m	1.25 mm ²	12 mm
210 to 300 m	2 mm ²	13 mm

ISO9001 and ISO14001 certified.



Misuse of this product can result in damages to property or human injury.
Read related manuals carefully before using this product.

Specifications are subject to change without notice.

Printed in Japan 2009-5 (TDOC)

© TOSHIBA Corporation 2008

All Rights Reserved.