

BATCH CONTROLLER

WITH TWO-STAGE CONTROL



Features

- Designed for batching / filling of liquids.
- Full keyboard with twenty industrial micro-switch keys.
- Alphanumeric display text in English, French, German or Dutch.
- Four styles of housing are available. Wall-mount housing comes as standard.
- Complete data back-up in the event of sudden power failure.
- User-friendly operation with clear menu structure.
- Adjustable sensor excitation 8 - 24V DC.
- No-flow monitoring.
- Automatic overrun correction.
- Record of total quantity batched.
- Two stage control.
- Record of number of batches executed.
- Easy and clearly structured operation.
- Modbus communications RS485.
- Flameproof enclosure ATEX:
 -  II 2 G EEx d IIB T5.

Control and alarm output

- Three, volt-free electro-mechanical relays with make and break contacts or solid state relays.

Signal input

Flow

- Reed-switch.
- NAMUR.
- NPN/PNP.

Applications

- Batching of liquids where the batch size changes frequently. Basic models: F030-F130 and F131 or more advance 0313, 0320 and 0330.

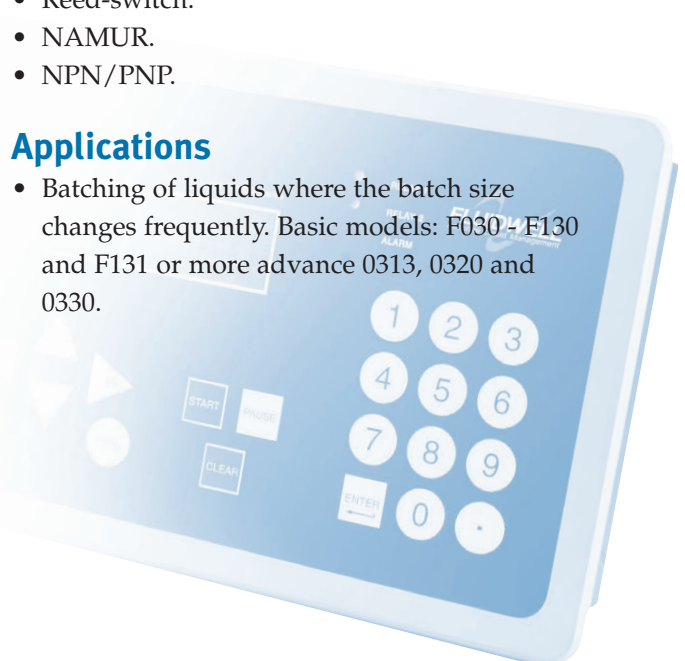

General information

Introduction

The Batch Controller model 310 has been developed for accurate filling and batching of liquids. The simplicity and structure, both for programming and during operation, ensures a reliable control and management of liquid flows. The numerical keyboard allows easy changing of the batch quantity desired. All functions are software controlled, offer broad application areas and user friendly control.

Screen display

An alphanumerical LCD display of 4 lines x 20 positions is integrated in the control panel. During the batch process the preset, actual batched quantity and flow rate are shown simultaneously; the process can be checked at a single glance. The clear display text is available in four languages.

Batch size

The preset value to be batched can be programmed directly by the operator. Repeating batches are executed easily with a start-command. Furthermore, the measuring unit and the number of decimals are programmable.

Overrun correction

The Fluidwell 310 measures the overrun quantity at the end of every batch. With the automatic overrun correction procedure, the batch is corrected automatically; every run is executed with the highest accuracy.

Flow rate

During the process, the instantaneous flow rate is computed and can be read from the display, (e.g. L/min).

Retained data

The total quantity of batched liquid and the number of batches are recorded. Under power failure conditions the actual process information is stored in the memory. This allows the process to be resumed from where it was interrupted.

Password protection

All settings, values and actions can be protected with a password selected by the customer. The level of protection can be set.

Relays

Two relays are available for the controlling of valves and / or a pump. With the two-stage control, the batch can be undertaken in one or two stages. Several functions are available to control both relays flexibly. The alarm relay is switched if a No-flow or external alarm is tripped. The LED's will flash and an audible alarm be initiated.

No-flow monitor

Following the START command, the flowmeter generates a signal. If this fails to come within the programmed time, an alarm is triggered. The batch is interrupted and the latest process values are stored in the memory. At the same time, the cause of the alarm is displayed. Alarm conditions are indicated audibly, visibly and by means of an alarm relay. The No-flow function detects the absence of liquid, an obstruction in the pipeline or a breakdown.

Communication

A serial interface (option) allows full computer control of the 310. The communication protocol used is Modbus ASCII/RTU.

Casings

Several enclosures are available to mount the batch controller in the most suitable way: with a wall-assembly or panel-mount casing or a EExd enclosure with a large LCD and keyboard.

Overview application 310

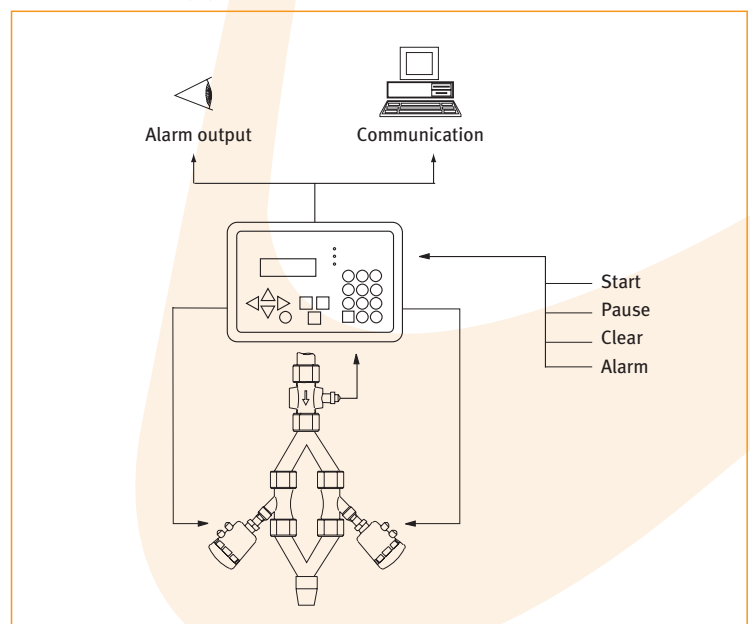

Dimensions enclosures

Enclosure HK (STANDARD)
Polystyrol wall mount casing IP50

dimensions: mm (inch)

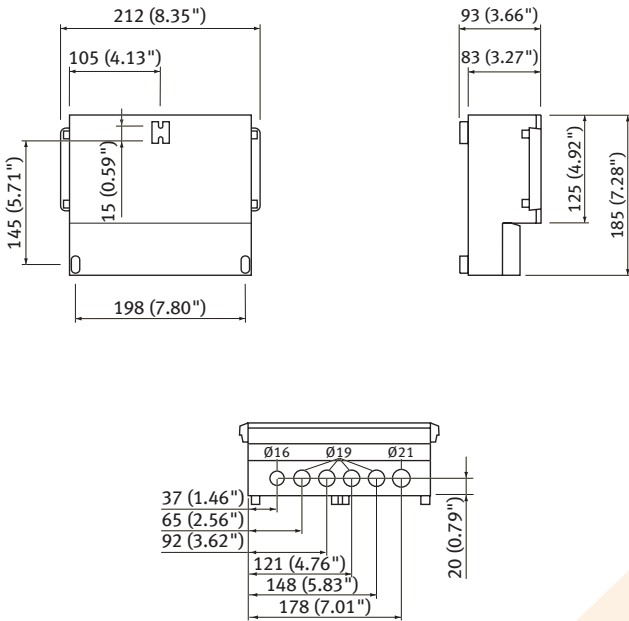

Enclosure HM

Panel-mount casing IP65

dimensions: mm (inch)

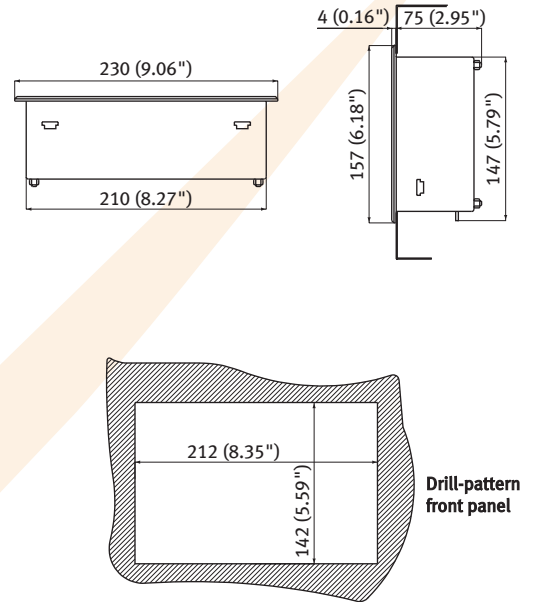

Enclosure HL
Polystyrol wall mount casing IP65 (frontdoor)

dimensions: mm (inch)

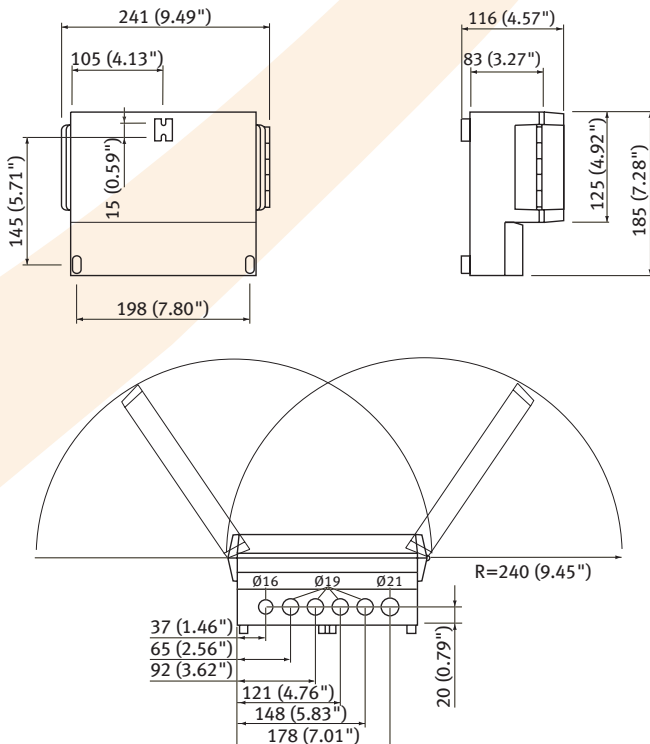

Enclosure HX

Compact explosion proof EExd casing IP54

dimensions: mm (inch)

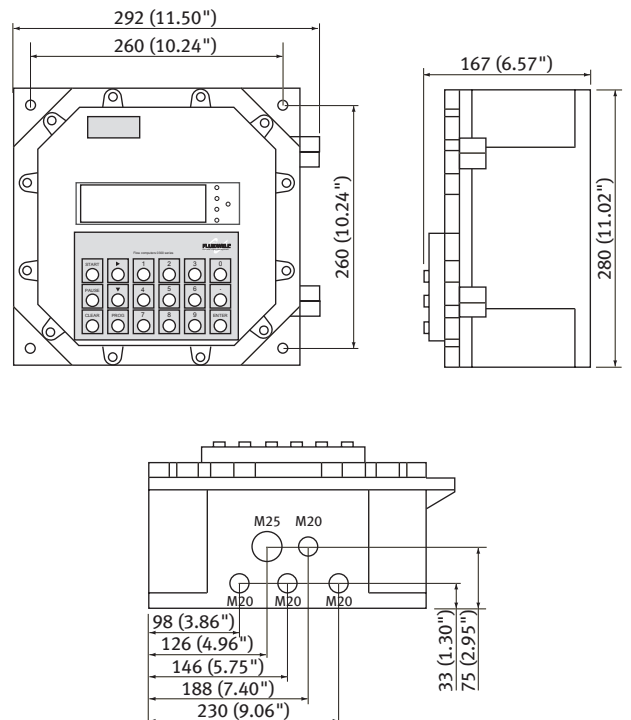

Terminal connections wall mount enclosures types: HK - HL - HX

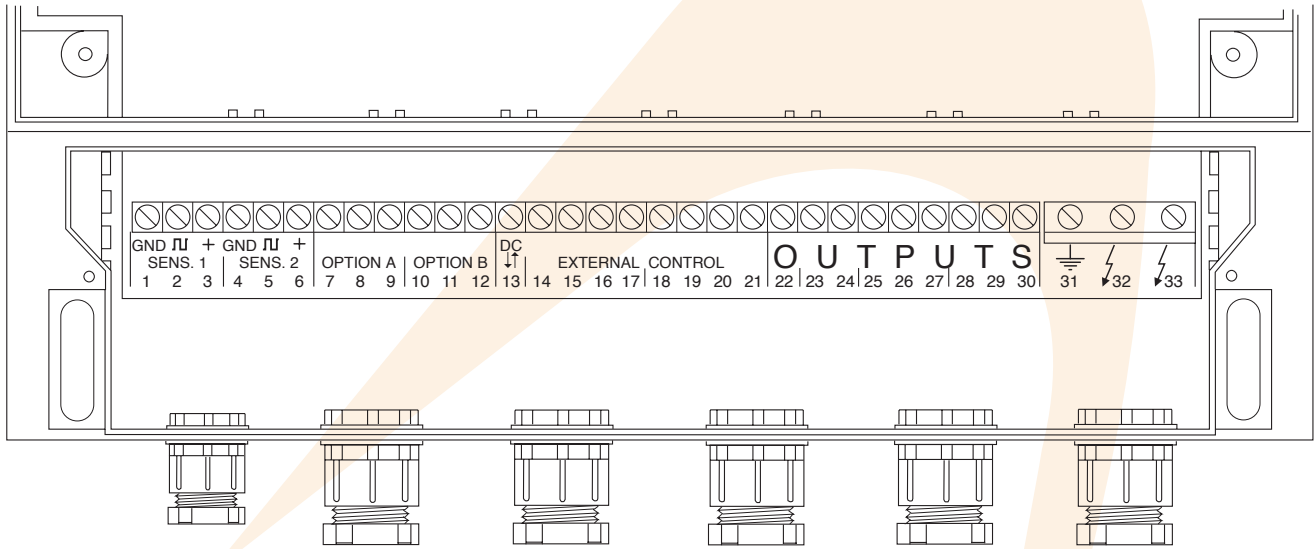

Terminal connections Panel mount enclosure type: HM

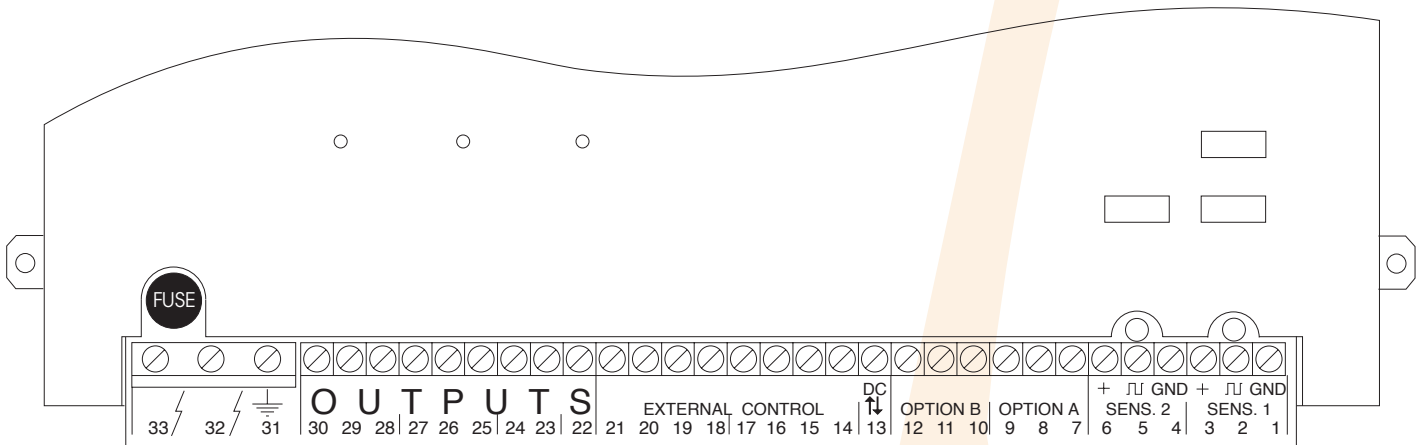

Explanation terminal connections

Terminal	Function	Explanation
01	sensor GND	Ground and shielding terminal.
02	sensor pulse	NPN or PNP pulse selected with a switch. Namur input has to be orderd.
03	sensor 12 / 24V DC	Votage selected with a switch. Namur sensor type supplies 8.2V DC.
04	not used.	
05	not used.	
06	not used.	
07	not used.	
08	not used.	
09	not used.	
10	RS232 / 485: GND	Communication opion.
11	RS232/485: RXD/a	Modbus ASCII / RTU. Maximum comm. speed 9600 baud.
12	RS232/485: TXD/b	Cable length RS232 max. 15 meters / RS485 max. 1200 meters.
13	external GND	By shortly connecting terminal 14, 15, 16 or 17 with connector 13 (GND).
14	external START	The functions START, PAUSE and CLEAR can be operated by remote control,
15	external PAUSE	or an alarm can be triggered.
16	external CLEAR	
17	external alarm	
18	not used.	
19	not used.	
20	not used.	
21	not used.	
22	alarm relay NO	Mech. relay: potential free make-and-break contact; max. switch power 1A - 230V AC.
23	alarm relay C	excited in normal condition(C and NO are connected); fail-safe.
24	alarm relay NC	
25	relay 1 NO / s.s. +	Mech. relay: potential free make-and-break contact; max. switch power 1A - 230V AC.
26	relay 1 C / s.s. -	Solid state relay: passive DC output; max. switch power 1A - 50V DC.
27	relay 1 NC / not used	Continuously excited during process.
28	relay 2 NO / s.s. +	Mech. relay: potential free make-and-break contact; max. switch power 1A -230V AC.
29	relay 2 C / s.s. -	Solid state relay: passive DC output; max. switch power 1A - 50V DC.
30	relay 2 NC / not used	Continuously during process or used as preclose relay for two stage control.
31	power supply	Earthing.
32	power supply	230V AC or 24V AC / DC or 12V AC / DC.
33	power supply	230V AC or 24V AC / DC or 12V AC / DC.

Technical specification

General

Display	
Type	Bright transfective alpha-numeric LCD with LED backlight.
Digits	4 lines (20 characters per line). Standard 5mm (0.2") digits; EExd enclosure 9mm (0.35") digits.
Refresh rate	Ten times a second.
Languages	English, German, French, Dutch.

Casing	
Type HK	Wall-mount IP50. Dimensions 212 x 185 x 93mm (8.35" x 7.28" x 3.66") - LxWxH.
Type HL	Wall-mount with front-door IP65. Dimensions 241 x 185 x 116mm (9.49" x 7.28" x 4.57") - LxWxH.
Type HM	Panel-mount IP65. Aluminium/stainless steel enclosure. Dimensions 230 x 157 x 79 mm (9.06" x 6.18" x 3.11") - LxWxH. Panel cut-out: 212 x 142mm (8.35" x 5.59") LxH.
Type HX	EExd enclosure IP54 – Die-cast aluminium. Cable entries: 1 x M25 – 4 x M20. Dimensions 292 x 280 x 167mm (11.50" x 11.02" x 6.57") - LxWxH.
Control keys	Twenty industrial micro-switch keys with tactile feedback and embossed design. UV-resistant polyester keypad. EExd version: eighteen rugged metal keys.

Operating temperature	
Operational	-10°C to +55°C (14°F to +131°F).

Power requirements	
Type PP	12V AC/DC - 15VA.
Type PR / PS	22 - 28V AC/DC - 15VA.
Type PT / PU	105 - 130V AC / 50Hz - 15VA.
Type PV / PW	210 - 240V AC / 50Hz - 15VA.

Sensor excitation	
Standard	Stabilized 12V DC or 24V DC - selection with voltage selection switch or 8.2 V DC when Namur input specified. Max. 100mA @ 24V DC.

Data protection	
Type	NVRAM backup of all settings including process data figures prior to any sudden or unexpected power failures. Data retention 10 years.

Hazardous area (optional)	
Explosion proof	Atex approved according to  II 2 G EEx d IIB T5. With 18 robust micro-switch keys. Compact case design.
Type XM	Operational temperature -20°C to +60°C (-4°F to +140°F). Includes automatic temperature compensated LCD contrast adjustment.

Environment	
CE	EMC compliant ref: EN50081 and EN50082.

Signal inputs

Pulse inputs	
Type P	NPN/PNP, open collector.
Type N	Namur type sensors.
Type S	Reed-switch.
Frequency	Minimum 0 Hz - maximum 10 KHz (18KHz) for total and flow rate.
K-factor	0.0001 - 9,999 with variable decimal position.

Logic inputs	
Function	Start / Pause / Clear / Alarm
Type	Four status inputs.
Voltage	8 - 24V DC supplied - external voltage max. 24V DC.
Duration	Minimum pulse duration 200µsec.

Signal outputs

Relay outputs	
Function	batching relays, alarm condition.
Type PP/PR/PT/PV	Three mechanical relays with volt-free make and break contacts.
Maximum load	1A - 230V AC/DC - Two relays protected with RC.
Type PS/PU/PW	Solid-state relays: max. load 1A - 50V DC.

Communication option (optional)	
Function	Reading display information, reading / writing all settings, driving printers, control a batch.
Type CH	RS485 (2-wire).
Protocol	Modbus ASCII / RTU.
Speed	1200 - 2400 - 4800 - 9600 baud.
Addressing	Maximum 255 addresses.

Operational

Operator functions	
Displayed functions	<ul style="list-style-type: none"> • Preset value. • Actual batched quantity. • Flow rate. • Total. • Batch counter.

Preset value / batched quantity	
Digits	7.
Units	mL, hL, L, m³, cc, gl, bb, gr, kg, Tn, pt, p, ...
Decimals	0 - 6.

Flow rate	
Units	mL, hL, L, m³, cc, gl, bb, gr, kg, Tn, pt, p, ...
Time	Minute / second.

Total	
Digits	7.
Units	mL, hL, L, m³, cc, gl, bb, gr, kg, Tn, pt, p, ...
Note	Total can be reset to zero.

Batch counter	
Digits	7.
Note	Counter can be reset to zero.

Enclosure HK (STANDARD)
Polystyrol wall mount casing IP50



Enclosure HM
Panel-mount casing IP65



Enclosure HL
Polystyrol wall mount casing IP65 (frontdoor)



Enclosure HX
Compact explosion proof EExd casing IP54



Display example

1A	BATCH SIZE:	1
ACTUAL	3450.58	L
PRESET	8500.00	L
FLOWR.	548.45	L/min

Ordering information

Example (standard configuration)

310-P-CX-HK-PV-XX-ZX.

Explanation standard configuration:

P: input signal: NPN/PNP; **CX**: no communication; **HK**: polystyrol wall mount casing IP50;
PV: 230V AC + mechanical relays; **XX**: Safe area; **ZX**: no options.

Ordering information:	310	-	-C	-H	-P	-X	-Z
Input signal							
N	Namur.						
P	NPN / PNP.						
S	Reed switch input.						
Communication							
CH	Communication RS485 - 2-wire - Modbus ASCII / RTU.						
CX	No communication.						
Enclosure							
HK	Polystyrol wall mount casing IP50.						
HL	Polystyrol wall mount casing IP65 (frontdoor).						
HM	Panel-mount casing IP65.						
HX	Explosion proof casing IP54 (type XM).						
Power supply and relays							
PP	12V AC / DC + mechanical relays.						
PR	24V AC / DC + mechanical relays.						
PS	24V AC / DC + solid state relays.						
PT	115V AC + mechanical relays.						
PU	115V AC + solid state relays.						
PV	230V AC + mechanical relays.						
PW	230V AC + solid state relays.						
Hazardous area							
XM	⊕ II 2 G EEx d IIB T5; 18 keys; -20°C / +60°C; 3 x M20 - 1 x M25.						
XX	Safe area only.						
Other options / Specials							
ZN	Remove RC-filter mechanical relays.						
ZX	No options.						

The bold marked text contains the standard configuration.

Specifications are subject to change without notice.

FLUIDWELL bv
P.O. Box 6
5460 AA - Veghel - The Netherlands
Tel.: +31 (0)413 343786
Fax.: +31 (0)413 363443
sales@fluidwell.com
Internet: www.fluidwell.com

