

SET-POINT GENERATOR

WITH ANALOG SENSOR INPUT,
ALARMS AND ANALOG OUTPUTS



Features

- Displays the actual process value and transmitted value simultaneously.
- Manual (0)4–20mA / 0–10V DC control output.
- Preset value can be entered as a scaled value (e.g. 415°C), analog value (e.g. 15,3mA) or as a percentage.
- Preset value: seven 17mm (0.67") digits during programming and 8mm (0.31") digits during process.
- Actual value: seven 17mm (0.67") digits during process.
- Modbus communication for remote control.
- Green LED backlight.
- Backup of settings in EEPROM memory.
- Very compact design for panel mount, wall mount or field mount applications.
- Rugged aluminum or GRP field mount enclosure IP67 / NEMA4X.
- Operational temperature -40°C up to +80°C (-40°F up to 176°F).
- Intrinsically Safe - ATEX and IECEx approval for gas and dust applications.
- Explosion/ flame proof  II 2 GD EEx d IIB T5.

Signal output

- 4 - 20mA / 0 - 10 V DC for transmitting any value set by the operator. The output is scaled manually by the operator or through Modbus communication - the output can be scaled to any range (e.g. from 0% to 110%).
- Alarm outputs for low or high signal input alarms.

Signal input

- (0)4 - 20mA.
- 0 - 10V DC.

Applications

- Manual set-point control of process variables requiring a (0)4 – 20mA or 0 – 10V DC input value. For example to tune temperature or flow rate manually.

General information

Introduction

The F197 is a manual set-point generator. The operator enters an analog or a scaled output value or a percentage which will be transmitted as a (0)4 – 20mA or 0 – 10V DC signal to a control device. An analog input signal is possible but not necessary. There is no direct control relationship between the input and output value. A wide range of options further enhance this models capabilities, including Intrinsic Safety for hazardous area applications and full Modbus communication.

Display

The display has large 17mm segments which can be set to show preset value, actual value and status simultaneously. On-screen engineering units are easily configured from a comprehensive menu.

Configuration

All configuration settings are accessed via a simple operator menu which can be passcode protected. Each setting is clearly indicated with an alphanumeric description, which avoids confusing abbreviations and baffling codes. Once familiar with one F-series product, you will be able to program all models in the series without a manual. All settings are safely stored in EEPROM memory in the event of sudden power loss.

Analog output signal

The analog output is transmitting any value, set by the operator. The output is scaled manually by the operator or through Modbus communication - the output can be scaled to any range (e.g. from 0% to 110%). The output signal is updated ten times per second. The output signal can be passive, active or isolated where the passive output type will loop power the F197 as well.

Alarm output

two configurable outputs are available to transmit the alarm condition for low or high signal input alarms. The output signals can be a passive NPN, active PNP or an isolated electro-mechanical relay.

Signal input

The F197 accepts analog input signals from flow, temperature, pressure or level input sensors. The input signal type can be selected by the user in the configuration menu without having to adjust any sensitive mechanical dip-switches or jumpers. Important: a sensor input signal is not required.

Communication

All process data and settings can be read and modified manually or through the Modbus communication link (RS232 / RS485). Full Modbus functionality remains available for the Intrinsically Safe version (TTL).

Hazardous areas

This model has been ATEX and IECEx certified Intrinsically Safe for gas and dust applications, with an allowed operational temperature of -40°C to +70°C (-40°F to +158°F).

A flame proof enclosure with ATEX certification offers the rating Ex II 2 GD EEx d IIB T5.

Enclosures

Various types of enclosures can be selected, all ATEX and IECEx approved. As standard the F197 is supplied in an GRP panel mount enclosure, which can be converted to an IP67 / NEMA 4X GRP field mount enclosure by the addition of a back case. Most popular is our rugged aluminum field mount enclosure with IP67 / NEMA 4X rating. Both European or U.S. cable gland entry threads are available.

Overview application F197

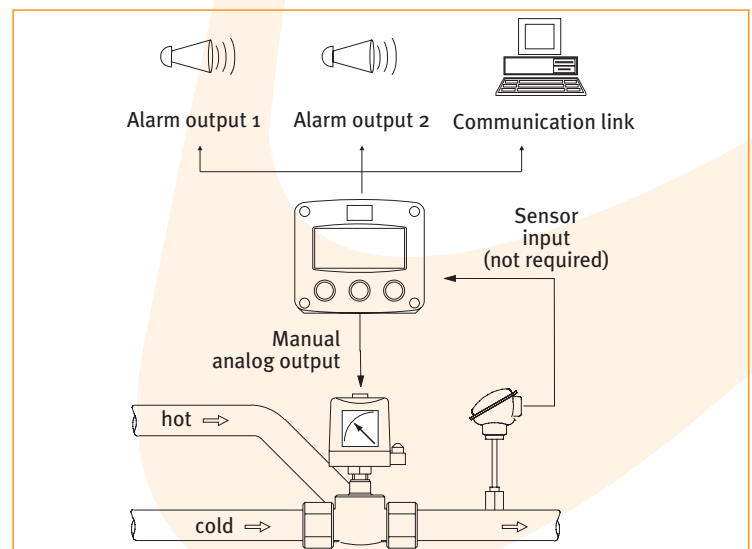

Dimensions enclosures

Aluminum & GRP panel mount enclosure

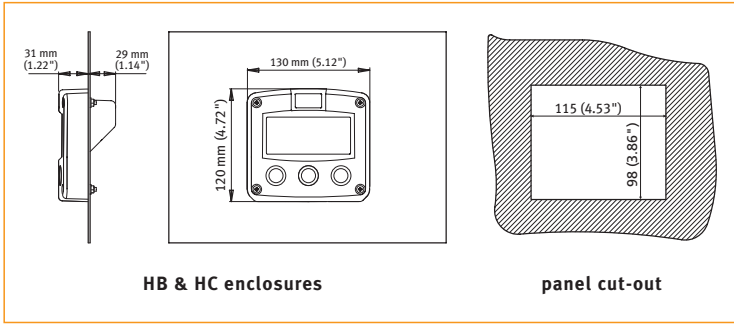

Aluminum & GRP field / wall mount enclosures

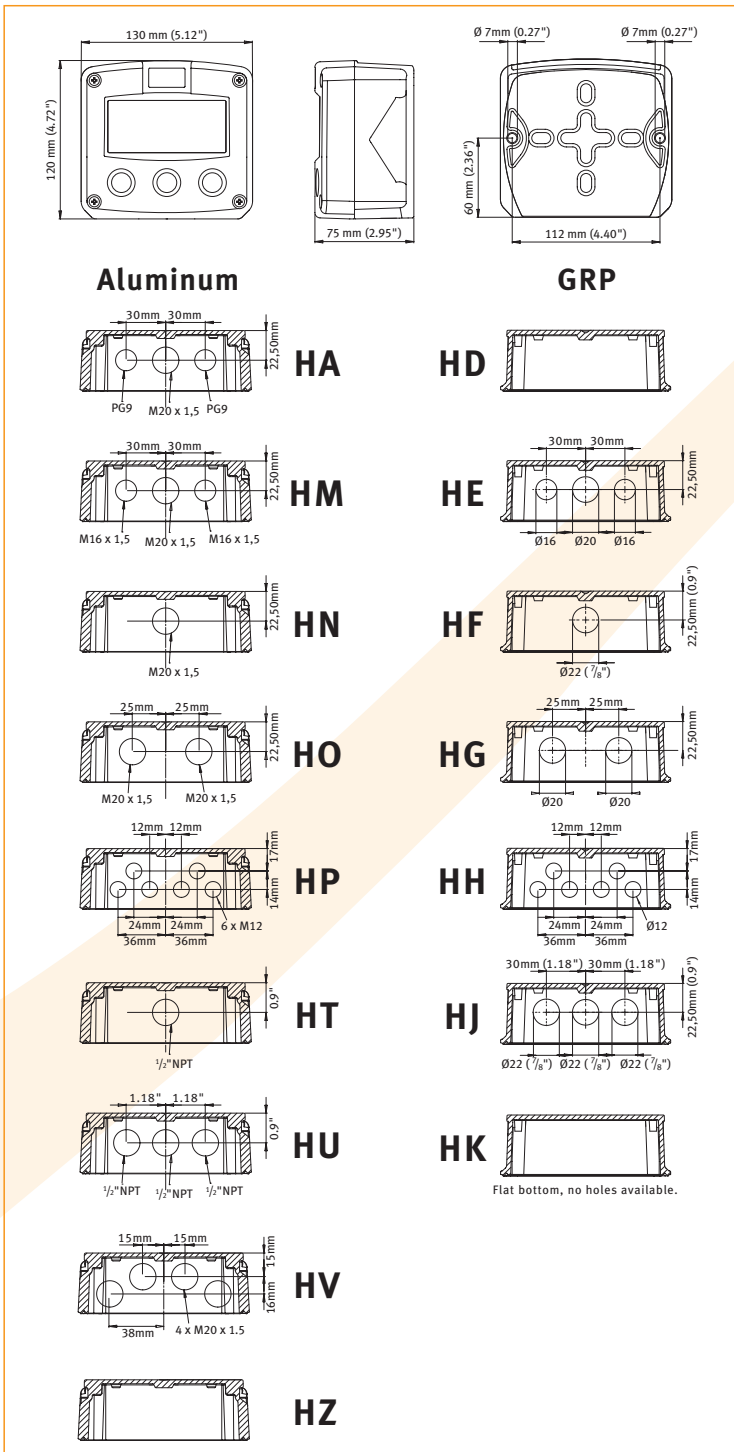

Terminal connections

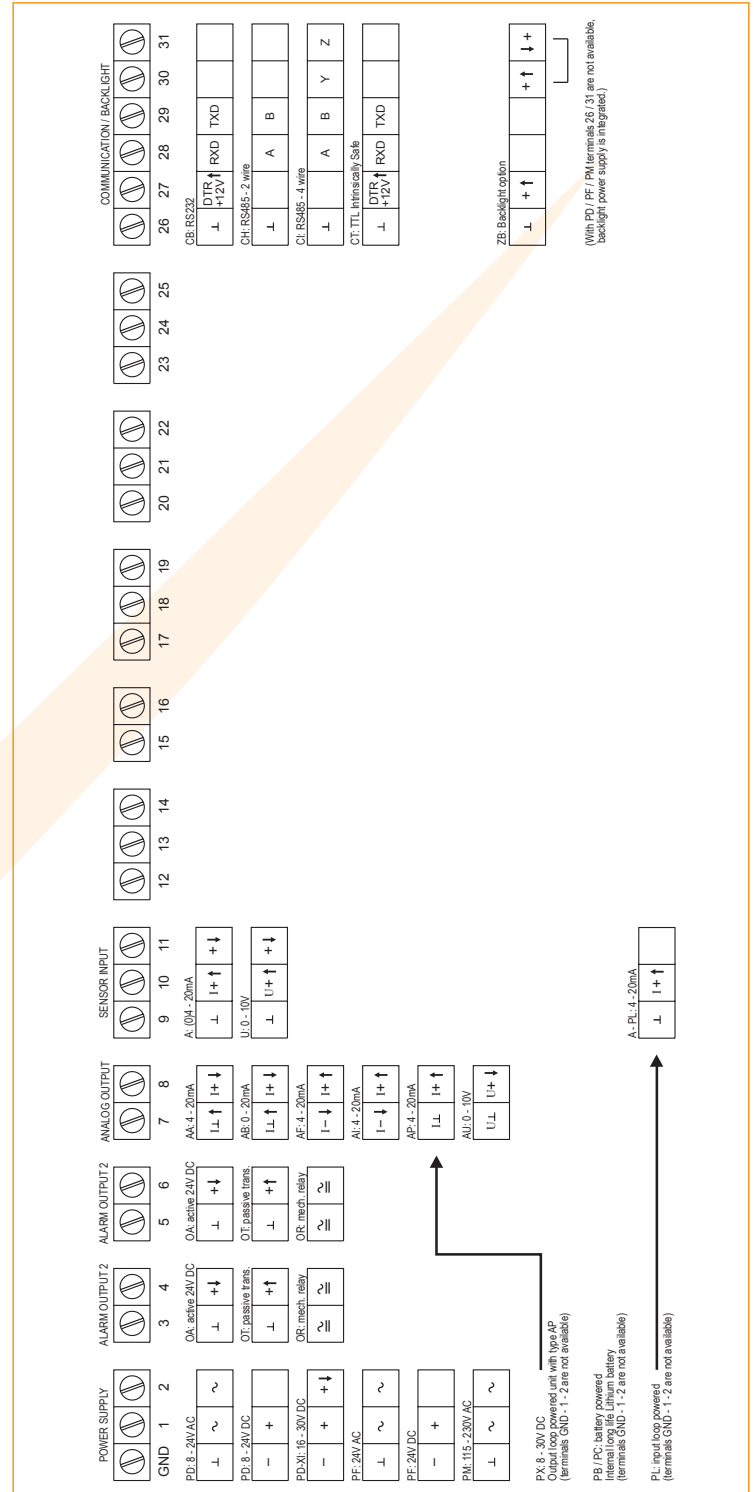

Display example - 90 x 40mm (3.5" x 1.6")

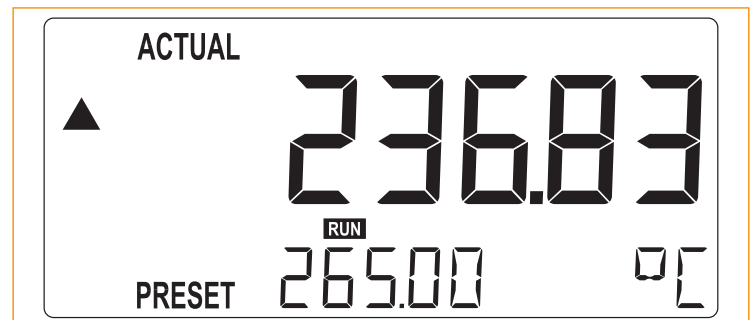

Typical wiring diagram F197-A-AI-CI-PL

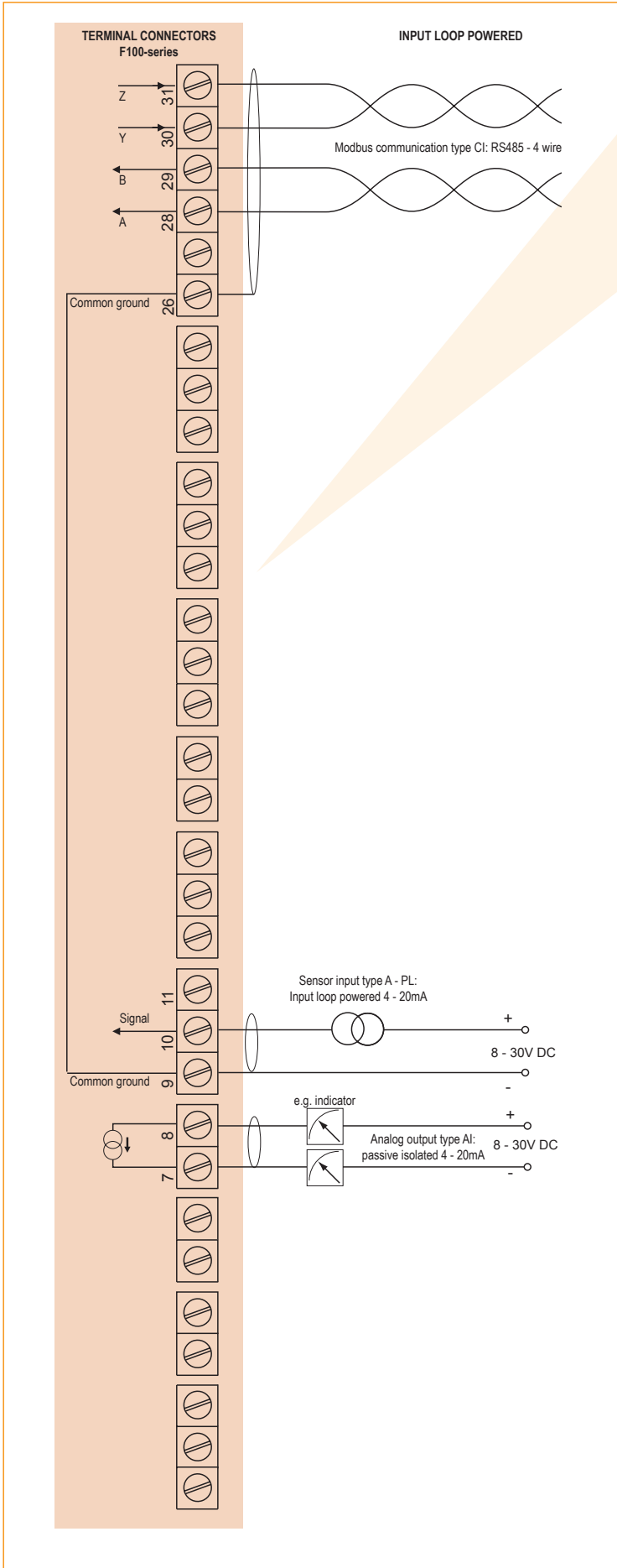

Typical wiring diagram F197-A-AP-CH-OT-PX

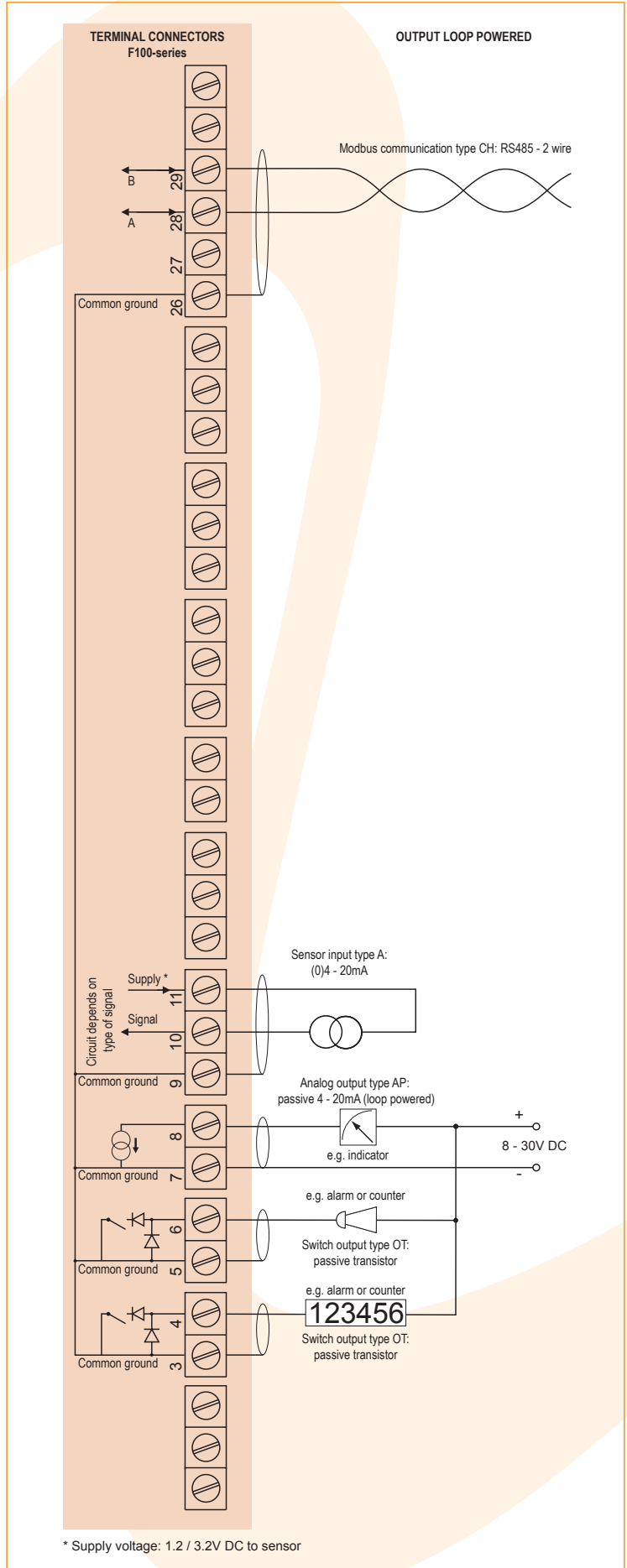

* Supply voltage: 1.2 / 3.2V DC to sensor

Typical wiring diagram F197-A-AA-CB-OA-PD

Typical wiring diagram F197-A-AI-CI-OR-PM

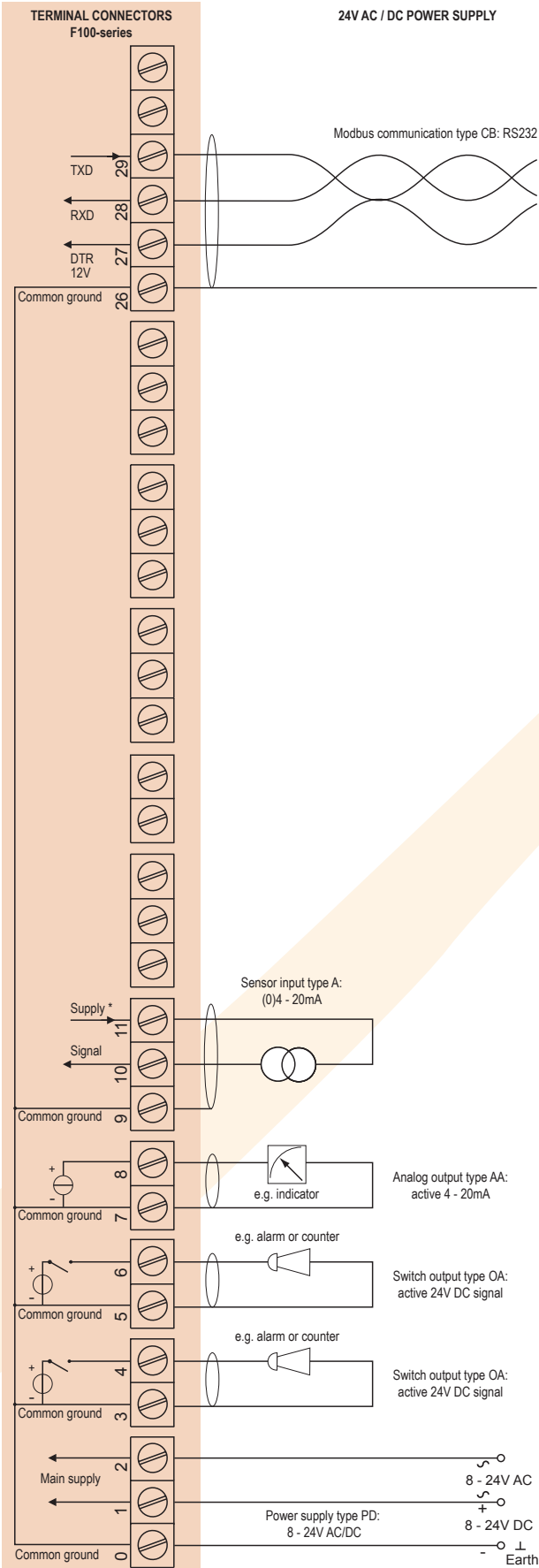

* Supply voltage: 3.2 / 8.2 / 12 / 24V DC to sensor

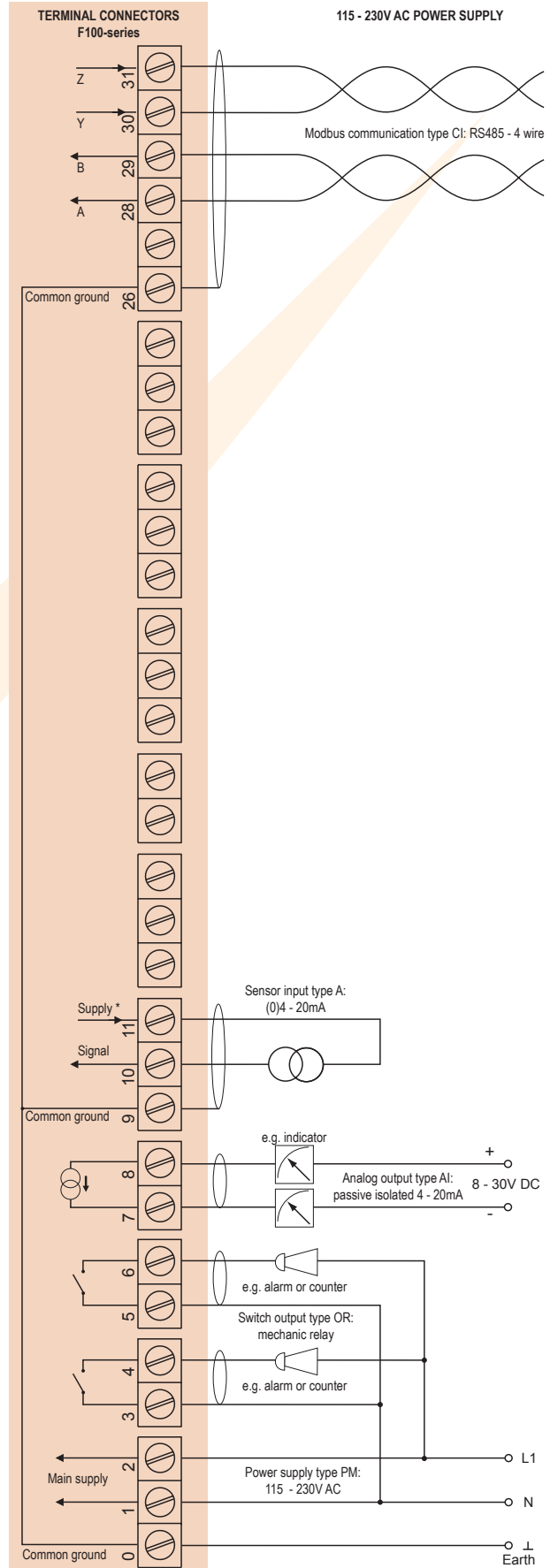

* Supply voltage: 3.2 / 8.2 / 12 / 24V DC to sensor

Hazardous area applications

The F197-XI has been certified according ATEX and IECEx by DEKRA for use in Intrinsically Safe applications with an ambient temperature of -40°C to +70°C (-40°F to +158°F).

- The ATEX markings for gas and dust applications are:

Ex II 1 G Ex ia IIB/IIC T4 Ga
Ex II 1 D Ex ia IIIC T100 TC Da IP6X.

- The IECEx markings for gas and dust applications are: **Ex ia IIC/IIB T4 Ga** and **Ex ia IIIC T100 TC Da IP6X.**

It is allowed to connect up to six barriers in IIB/IIIC applications or one barrier in IIC applications. Consult the certificate for the maximum input and output values of the circuits. Full functionality of the F197 remains available, including 8.2V sensor excitation for e.g. Namur sensors (type PD) and the Modbus communication type CT. A flame proof enclosure is available as well with rating ATEX **Ex II 2 GD EEx d IIB T5**. Please contact your supplier for further details.

Certificate of conformity KEMA 03ATEX1074 X

- IECEx DEK 11.0042X

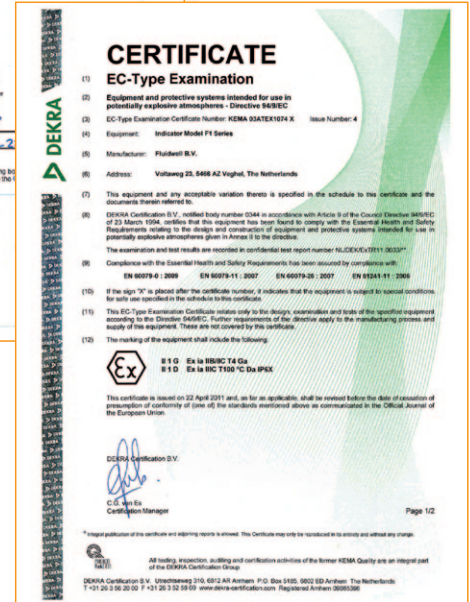
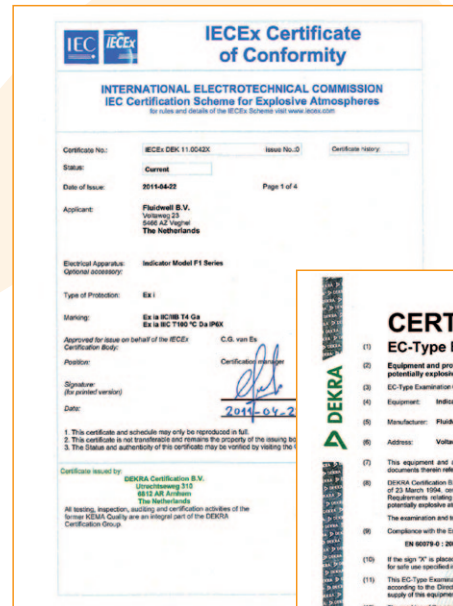

Configuration example IIB / IIIC and IIC- F197-AP-OT-PX-XI - Output loop powered

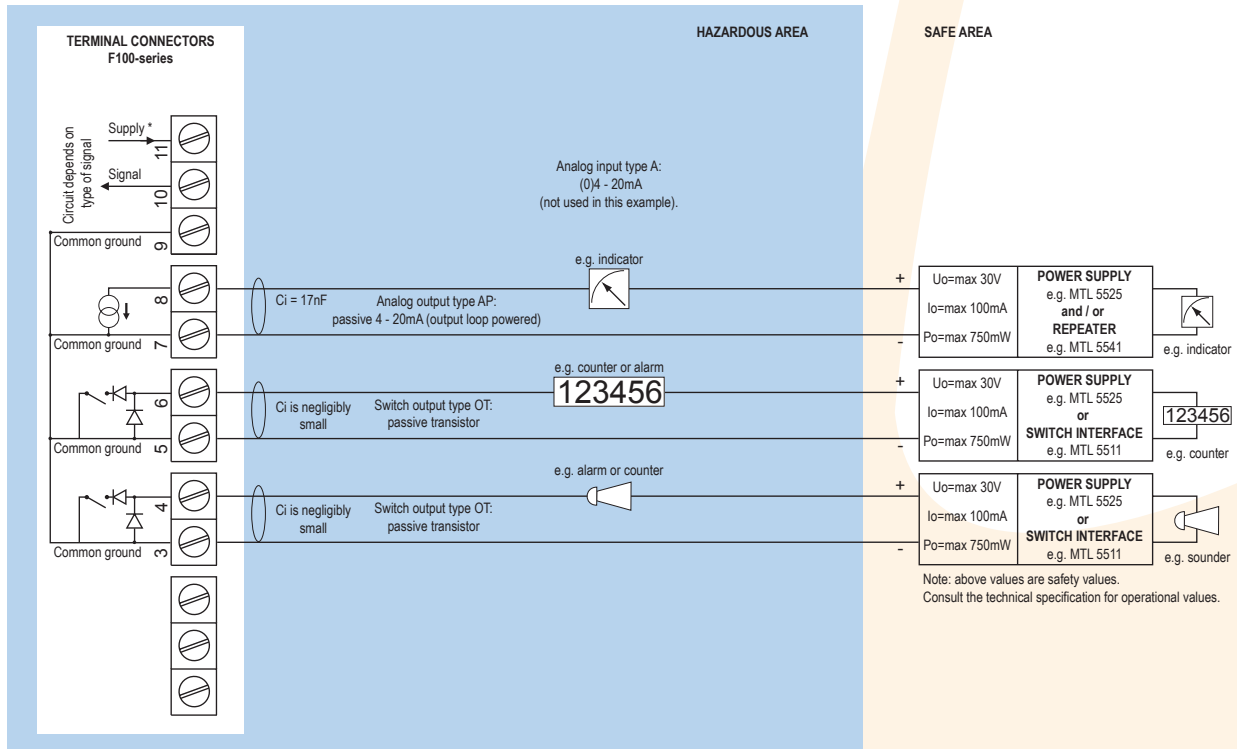

Configuration example IIB / IIIC and IIC - F197-A-AF-CT-OT-PD-XI - Power supply 16 - 30V DC

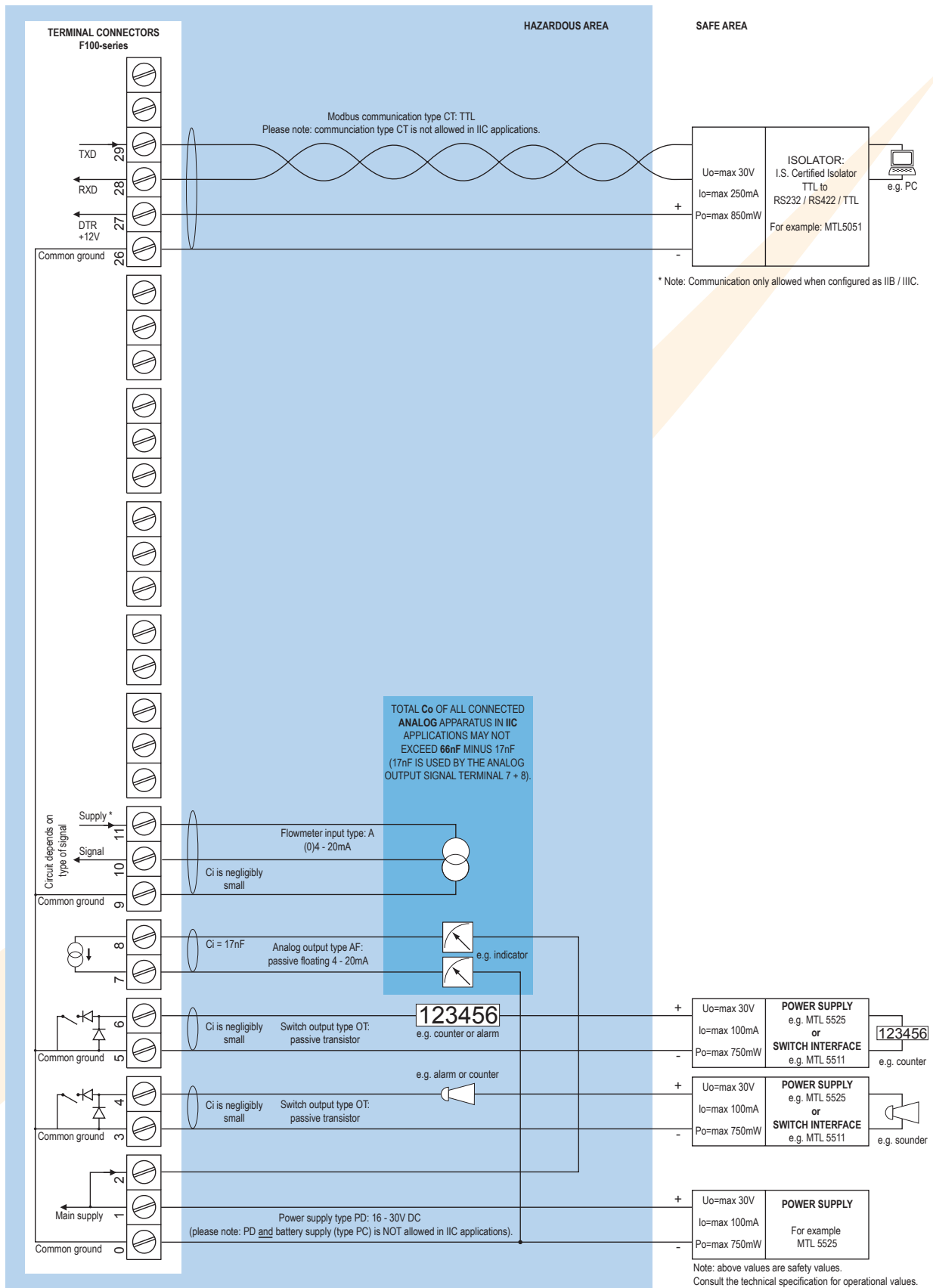

* Note power supply type PD: the supply voltage to pulse sensors is maximum 8.7V (U_o=max 8.7V I_o=max 25mA P_o=max 150mW) and to analog sensors as connected to terminal 1 (internally linked).

Technical specification

General

Display	
Type	High intensity reflective numeric and alphanumeric LCD, UV-resistant.
Dimensions	90 x 40mm (3.5" x 1.6").
Digits	Seven 17mm (0.67") and eleven 8mm (0.31") digits. Various symbols and measuring units.
Refresh rate	User definable: 8 times/sec. - 1 time/30 secs.
Option ZB	Transflective LCD with green LED backlight. Good readings in full sunlight and darkness.
Note ZB	Only available for safe area applications.

Operating temperature

Standard unit	-40°C to +80°C (-40°F to +176°F).
Intrinsically Safe	-40°C to +70°C (-40°F to +158°F).

Power requirements

Type PB	Long life Lithium battery - life-time depends upon settings and configuration - up to 5 years.
Type PC	Intrinsically Safe long life lithium battery - life-time depends upon settings and configuration - up to 5 years.
Type PD	8 - 24V AC / DC \pm 10%. Power consumption max. 10 Watt. Intrinsically Safe: 16 - 30V DC; power consumption max. 0.75 Watt.
Type PF	24V AC / DC \pm 10%. Power consumption max. 15 Watt.
Type PL	Input loop powered from sensor signal 4 - 20mA (type "A") - requires types AI or AF and OT (not Xi).
Type PM	115 - 230V AC \pm 10%. Power consumption max. 15 Watt.
Type PX	8 - 30V DC. Power consumption max. 0.5 Watt.
Type ZB	12 - 24V DC \pm 10% or internally powered with type PD / PF / PM. Power consumption max. 1 Watt.
Note PB/PF/PM	Not available Intrinsically Safe.
Note PF/PM	The total consumption of the sensors and outputs may not exceed 400mA @ 24V.
Note	For Intrinsically Safe applications, consult the safety values in the certificate.

Sensor excitation

Type PB/PC/PX	3.2V DC.
Type PD	3.2 / 8.2 / 12 / 24V DC - max. 50mA@24V DC.
Type PD-XI	3.2 / 8.2V DC - max. 7mA@8.2V DC and mains power supply voltage (as connected to terminal 1).
Note	In case PD-XI and signal input type A or U, the sensor supply voltage will be according to power supply as connected to terminal 1.
Type PF / PM	3.2 / 8.2 / 12 / 24V DC - max. 200mA@24V DC.

Terminal connections

Type	Removable plug-in terminal strip. Wire max. 1.5mm ² and 2.5mm ² .
------	--

Data protection

Type	EEPROM backup of all settings. Data retention at least 10 years.
Pass-code	Configuration settings can be pass-code protected.

Casing

General

Window	Polycarbonate window.
Sealing	Silicone.
Control keys	Three industrial micro-switch keys. UV-resistant silicone keypad.

Aluminum wall / field mount enclosures

General	Die-cast aluminum wall/field mount enclosure IP67 / NEMA 4X with 2-component UV-resistant coating.
Dimensions	130 x 120 x 75mm (5.12" x 4.72" x 2.95") - W x H x D.
Weight	1100 gr.
Type HA	Cable entry: 2 x PG9 and 1 x M20.
Type HM	Cable entry: 2 x M16 and 1 x M20.
Type HN	Cable entry: 1 x M20.
Type HO	Cable entry: 2 x M20.
Type HP	Cable entry: 6 x M12.
Type HT	Cable entry: 1 x 1/2" NPT.
Type HU	Cable entry: 3 x 1/2" NPT.
Type HV	Cable entry: 4 x M20.
Type HZ	Cable entry: no holes.

GRP wall / field mount enclosures

General	GRP wall/field mount enclosure IP67 / NEMA 4X, UV-resistant and flame retardant.
Dimensions	130 x 120 x 75mm (5.12" x 4.72" x 2.95") - W x H x D.
Weight	600 gr.
Type HD	Cable entry: no holes.
Type HE	Cable entry: 2 x \varnothing 16mm and 1 x \varnothing 20mm.
Type HF	Cable entry: 1 x \varnothing 22mm (7/8").
Type HG	Cable entry: 2 x \varnothing 20mm.
Type HH	Cable entry: 6 x \varnothing 12mm.
Type HJ	Cable entry: 3 x \varnothing 22mm (7/8").
Type HK	Flat bottom, cable entry: no holes.

Panel mount enclosures



Dimensions	130 x 120 x 60mm (5.12" x 4.72" x 2.36") - W x H x D.
Panel cut-out	115 x 98mm (4.53" x 3.86") L x H.
Type HB	Die-cast aluminum panel mount enclosure IP65 / NEMA 4X.
Weight	600 gr.
Type HC	GRP panel mount enclosure IP65 / NEMA 4X, UV-resistant and flame retardant.
Weight	450 gr.

ABS wall / field mount enclosures

General	Silicone free ABS wall/field mount enclosure IP65 with EPDM and PE sealings. UV-resistant polyester keypad (old HD enclosure).
Dimensions	130 x 114 x 71mm (5.1" x 4.5" x 2.8") - W x H x D.
Weight	450 gr.
Type HS	Cable entry: no holes.

Hazardous area

Intrinsically Safe (Type XI)

ATEX certification	 II 1 G Ex ia IIB/IIC T4 Ga. II 1 D Ex ia IIC T100 °C Da IP6X.
IECEX certification	 Ex ia IIC/IIB T4 Ga. Ex ia IIC T100 °C Da IP6X.
Ambient Ta	-40°C to +70°C (-40°F to +158°F).

Explosion proof (Type XF)

ATEX certification	 II 2 GD EEx d IIB T5.
Dimensions	300 x 250 x 200mm (11.8" x 9.9" x 7.9") L x H x D.
Weight	Appr. 15kg.

Environment

Electromagnetic compatibility	Compliant ref: EN 61326 (1997), EN 61010-1 (1993).
-------------------------------	--

Signal inputs

Sensor signal

Type A	(0)4 - 20mA. Analog input signal can be scaled to any desired range within 0 - 20mA.
Type U	0 - 10V DC. Analog input signal can be scaled to any desired range within 0 - 10V DC.
Accuracy	14 bit. Error < 0.05%. Low level cut-off programmable.
Span	0.000010 - 9,999,999 with variable decimal position.
Offset	-999,999 - +999,999 units.
Update time	Four times per second.
Voltage drop	Type A: 2.5V@20mA.
Load impedance	Type U: 3kΩ.
Relationship	Linear and square root calculation.
Note	For signal type A and U: external power to sensor is required; e.g. type PD.
Note	A sensor input signal is not required.

Signal outputs

Analog output

Function	Transmitting any value set by the operator.
Accuracy	10 bit. Error < 0.05%. Analog output signal can be scaled to any desired range.
Update time	Ten times per second.
Type AA	Active 4 - 20mA output (requires PD, PF or PM).
Type AB	Active 0 - 20mA output (requires PD, PF or PM).
Type AF	Passive floating 4 - 20mA output for Intrinsically Safe applications (requires XI + PC or PD).
Type AI	Passive galvanically isolated 4 - 20mA output - also available for battery powered models (requires PB, PD, PF, PL or PM).
Type AP	Passive 4 - 20mA output - not isolated. Unit will be loop powered.
Type AU	Active 0 - 10V DC output (requires PD, PF or PM).

Alarm output

Function	Low or high signal input alarms.
Frequency	Max. 64Hz. Pulse length user definable between 7.8 msec up to 2 seconds.
Type OA	Two active 24V DC transistor outputs (PNP); max. 50mA per output (requires PD, PF or PM).
Type OR	Two electro-mechanical relay outputs (N.O.) - isolated; max. switch power 230V AC - 0.5A per relay (requires PF or PM).
Type OT	Two passive transistor outputs (NPN) - not isolated.

Communication option

Function	Reading display information, reading / writing all configuration settings.
Protocol	Modbus RTU.
Speed	1200 - 2400 - 4800 - 9600 baud.
Addressing	Maximum 255 addresses.
Type CB	RS232
Type CH	RS485 2-wire
Type CI	RS485 4-wire
Type CT	TTL Intrinsically Safe.

Operational

Operator functions

Displayed functions	<ul style="list-style-type: none"> • Enter a setpoint value. • Enter alarm high and low value. • Preset value and actual value (if available).
---------------------	---

Preset / Setpoint

Digits	6 digits: -999,999 to +999,999 units or 4 digits: 0 to 999.9% or mA.
Units	No unit - mm - cm - m - meter - mil - in - ft - yd - fath - sqft - ml - l - nl - al - m ³ - nm ³ - am ³ - gal - usgal - igal - bbl - cuft - mg - g - kg - ton - oz - lb - st - qr - cwt - psi - psig - mbar - mbarg - bar - barg - pa - pag - kpa - kpag - mmh ₂ o - mh ₂ o - inh ₂ o - mmhg - inhg - °C - °F - K - p - rpm - % - ppm or mA.
Decimals	0 - 1 - 2 or 3.
Time units	/sec - /min - /hr - /day.

Alarm values

Digits	6 digits.
Units	According to selection for setpoint.
Decimals	According to selection for setpoint.
Time units	According to selection for setpoint.
Type of alarm	Low or high actual alarm. Includes delay time alarm.

Accessories

Mounting accessories

ACFo2	Stainless steel wall mounting kit.
ACFo5	Stainless steel pipe mounting kit (worm gear clamps not included).
ACFo6	Two stainless steel worm gear clamps Ø 44 - 56mm.
ACFo7	Two stainless steel worm gear clamps Ø 58 - 75mm.
ACFo8	Two stainless steel worm gear clamps Ø 77 - 95mm.
ACFo9	Two stainless steel worm gear clamps Ø 106 - 138mm.
ACF10	Customized Grevopal tagplates for ACFo2 and ACFo5, including stainless steel screws. Dimension: 95mm x 12.5mm (3.75" x 0.50").

Cable gland accessories

ACF20	For HA enclosure, includes O-rings.
ACF25	For HE enclosure, includes locknuts and O-rings.
ACF26	For HF enclosure, includes locknuts and O-rings.
ACF27	For HG enclosure, includes locknuts and O-rings.
ACF28	For HH enclosure, includes locknuts and O-rings.
ACF29	For HJ enclosure, includes locknuts and O-rings.
ACF32	For HM enclosure, includes O-rings.
ACF33	For HN enclosure, includes O-rings.
ACF34	For HO enclosure, includes O-rings.
ACF35	For HP enclosure, includes O-rings.
ACF39	For HT enclosure, includes O-rings.
ACF40	For HU enclosure, includes O-rings.

Ordering information

Standard configuration: F197-P-AP-CX-EX-HC-IX-OT-PX-TX-XX-ZX.

Ordering information: F197 _ -A _ -C _ -EX -H _ -IX -O _ -P _ -TX -X _ -Z _

Sensor input signal (not required)

- A (o)4 - 20mA input.
- U 0 - 10V DC input.

Analog output signal

- AA Active 4 - 20mA output - requires PD, PF or PM.
- AB Active 0 - 20mA output - requires PD, PF or PM.
- AF I.S. floating 4 - 20mA output - requires XI + PC or PD.
- AI Isolated 4 - 20mA output - requires PB, PD, PF, PL or PM.
- AP Passive 4 - 20mA output, loop powered unit.**
- AU Active 0 - 10V DC output - requires PD, PF or PM.

Communication

- CB Communication RS232 - Modbus RTU.
- CH Communication RS485 - 2wire - Modbus RTU.
- CI Communication RS485 - 4 wire - Modbus RTU.
- CT Intrinsically Safe TTL - Modbus RTU.
- CX No communication.**

Flow equations

- EX No flow equations.**

Panel mount enclosures - IP65 / NEMA4X

- HB Aluminum enclosure.
- HC GRP enclosure.**

GRP field / wall mount enclosures - IP67 / NEMA4X

- HD Cable entry: no holes.
- HE Cable entry: 2 x Ø 16mm & 1 x Ø 20mm.
- HF Cable entry: 1 x Ø 22mm (7/8").
- HG Cable entry: 2 x Ø 20mm.
- HH Cable entry: 6 x Ø 12mm.
- HJ Cable entry: 3 x Ø 22mm (7/8").
- HK Flat bottom, cable entry: no holes.

Aluminum field / wall mount enclosures - IP67 / NEMA4X

- HA Cable entry: 2 x PG9 & 1 x M20.
- HM Cable entry: 2 x M16 & 1 x M20.
- HN Cable entry: 1 x M20.
- HO Cable entry: 2 x M20.
- HP Cable entry: 6 x M12.
- HT Cable entry: 1 x 1/2" NPT.
- HU Cable entry: 3 x 1/2" NPT.
- HV Cable entry: 4 x M20.
- HZ Cable entry: no holes.

ABS field / wall mount enclosures - IP65

- HS Silicone free ABS field enclosure – Cable entry: no holes (old HD enclosure).

Additional inputs

- IX No additional input.**

Outputs

- OA Two active transistor outputs - requires PD, PF or PM.
- OR Two mechanical relay outputs - requires PF or PM.
- OT Two passive transistor outputs - standard configuration.**

Power supply

- PB Lithium battery powered.
- PC Lithium battery powered - Intrinsically Safe.
- PD 8 - 24V AC / DC + sensor supply - with XI: 16 - 30V DC.
- PF 24V AC / DC + sensor supply.
- PL Input loop powered from sensor signal type "A" - requires AI or AF and OT (not Xi).
- PM 115 - 230V AC + sensor supply.
- PX No power supply option. Unit requires external loop AP.**

Temperature input signal

- TX No temperature input signal.**

Hazardous area

- XI Intrinsically Safe, according ATEX and IECEx.
- XF EExd enclosure - 3 keys.
- XX Safe area only.**

Other options

- ZB Backlight.
- ZX No options.**

The bold marked text contains the standard configuration.

⊗ Available Intrinsically Safe.

Specifications are subject to change without notice.



Fluidwell bv
P.O. Box 6
5460 AA - Veghel - The Netherlands
Tel.: +31 (0)413 343786
Fax.: +31 (0)413 363443
sales@fluidwell.com
Internet: www.fluidwell.com

